



Valves

submittal sheet

# DCDALF4A/DCDA2LF4A series

double check detector assembly

lead free



USC-FCCCHR



job name:	
job location:	
engineer:	
contractor:	
tag:	
po#:	
rep:	
wholesale dist.:	

## description

the 2-1/2" - 12" double check detector assembly shall be an Apollo model DCDALF 4A or DCDA2LF 4A. the assembly shall be manufactured in America and carry a 5-year Apollo factory warranty. the TriForce™ center-stem guided check valves shall feature reversible silicone rubber seat discs. the check valves shall be held in place by SS snap-in retainers (2-1/2" - 6") or SS studs & nuts (8" - 12"). Access to the check valves shall be by an Apollo quick-connect SS coupling (2-1/2" - 6") or grooved couplings (8" - 12"). The bodies shall be domestic SS in 22-1/2" - 8" sizes and FDA epoxy-coated ductile iron in 10" & 12" sizes. the assembly consists of a mainline double check valve with a type 2 bypass (Type 1 optional) consisting of a lead free\* single check (SCV) and meter bypassing the mainline second check to prevent backflow while accurately measuring all flows up to 2 gpm while the mainline 2nd check remains closed. assemblies with the optional type 1 bypass consist of a lead free\* double check valve and meter which bypass both mainline checks and accurately meter all flows up to 2 gpm with the mainline checks closed. the Apollo lead free\* ball valve test cocks shall have SS handles. the pressure drop across the assembly shall be documented by an independent laboratory. the assembly shall prevent contamination of the potable water supply due to back-siphonage or backpressure from substances that are non-health hazards.

## features

- domestic stainless steel body: 2-1/2" - 8"
- fda epoxy-coated ductile iron body: 10" & 12"
- easy maintenance - no special tools required
- snap-in check retainers: 2-1/2" - 6"
- bolted-in checks: 8" - 12"
- low pressure loss as documented by an independent laboratory
- center-stem guided triforce™ check valves
- approved for horizontal (2-1/2"-12") and vertical flow up (2-1/2" - 8")
- US patent Nos. 6,443,184; 7,025,085; 7,533,699
- made in the USA (D option)
- 5 year warranty

## performance rating

- maximum working pressure: 175 psi
- temperature range: 33° F - 140° F
- hydrostatic test pressure: 350 psi

## approvals

- ASSE 1048\*, CSA B64.5, FM, UL\*, cUL\*
- NSF/ANSI 61 - water quality
- NSF/ANSI 372 - lead free
- approved by the foundation for cross-connection control and hydraulic research at the university of southern california (2-1/2" - 8" Type 1 & Type 2, 10" - 12" type 2 only)

\*ASSE, UL, and cUL installations must include indicating-type shut-off valves

## standard materials list

body (2-1/2" - 8")	304 stainless steel
body (10" & 12")	FDA epoxy coated ductile iron
covers (2-1/2" - 6")	glass-filled PPO/stainless steel
covers (8")	304 stainless steel
covers (10" & 12")	FDA epoxy coated ductile iron
check valves (2-1/2" - 12")	glass-filled PPO/bronze (C89836 lead-free*)/SS
bypass	lead free bronze C89836
springs	stainless steel
seat discs	chloramine-resistant silicone
test cocks	lead free bronze C89836 w/ SS handles

## part number matrix

4ALF	6 X	X	X	X X	X
	BYPASS SUB-ASSEMBLY OPTIONS	SIZE	METER OPTION	SHUT-OFF VALVES (INLET x OUTLET)	OPTIONS
4ALF - LEAD FREE	0 - TYPE 1 W/ 1/2" DOUBLE CHECK	9 - 2-1/2"	C - CUBIC FT/MIN	03 - OS&Y FLANGE X OS&Y FLANGE	D - DOMESTIC ASSEMBLY
	2 - TYPE 2 W/ 1/2" SINGLE CHECK (STD)	0 - 3"	E - GALLONS/MIN	04 - OS&Y FLANGE X MONITORED (MON.) BUTTERFLY VALVE GROOVE <sup>1</sup>	
	3 - TYPE 1 W/ BYPASS ON LEFT*	A - 4"	G - LESS METER	06 - OS&Y FLANGE X POST INDICATOR FLANGE	
	4 - TYPE 2 W/ BYPASS ON LEFT*	C - 6"		07 - OS&Y FLANGE X OS&Y GROOVE	
		E - 8"		08 - OS&Y GROOVE X OS&Y GROOVE	
		G - 10"		09 - MON. BUTTERFLY VALVE GROOVE X MON. BUTTERFLY VALVE GROOVE <sup>1</sup>	
		H - 12"		10 - OS&Y FLANGE X POST INDICATOR GROOVE	
				13 - POST INDICATOR FLANGE X MON. BUTTERFLY VALVE GROOVE <sup>1</sup>	
				14 - POST INDICATOR FLANGE X POST INDICATOR FLANGE	
				16 - MON BUTTERFLY VALVE GROOVE X POST INDICATOR FLANGE <sup>1</sup>	
				17 - POST INDICATOR FLANGE X OS&Y GROOVE	
				18 - OS&Y GROOVE X POST INDICATOR GROOVE	
				19 - MON. BUTTERFLY VALVE GROOVE X POST INDICATOR GROOVE	
				20 - POST INDICATOR FLANGE X OS&Y FLANGE	
				21 - POST INDICATOR GROOVE X OS&Y GROOVE	
				22 - POST INDICATOR GROOVE X MON. BUTTERFLY VALVE GROOVE <sup>1</sup>	
				23 - MON. BUTTERFLY VALVE GROOVE X OS&Y FLANGE	

EXAMPLE: 4ALF 60A E3 = 4" size lead free double check detector assembly with OS&Y flanged inlet x OS&Y flanged outlet shut-off valves w/ meter in gallons.

<sup>1</sup>orientation of bypass looking downstream. standard is right hand side. left hand is on opposite side

<sup>2</sup>butterfly valves not available in 12" size.

\*lead free: the wetted surfaces of this product shall contain no more than 0.25% lead by weighted average. complies with federal public law 111-380. ANSI 3rd party approved and listed.

# DCDALF4A/DCDA2LF4A series

double check detector assembly  
**lead free**

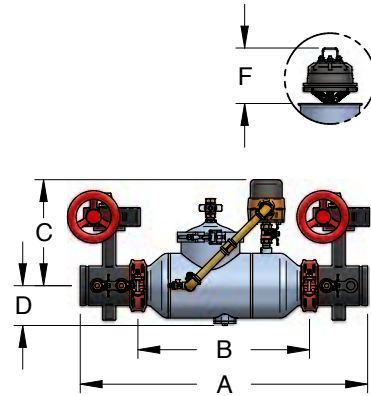
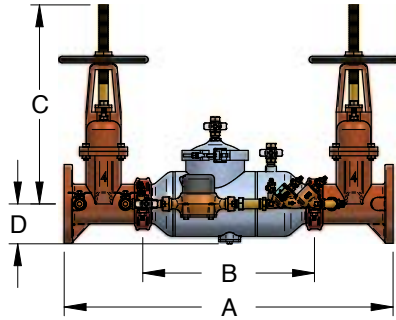
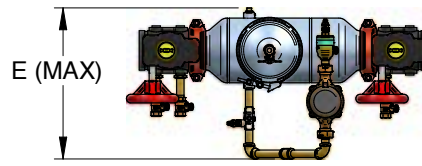
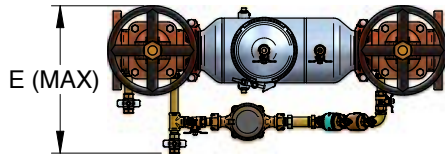

internal component removal space requirements

**type 1 bypass**

4" DCDALF4A w/ OS&Y gates shown

**type 2 bypass**

4" DCDA2LF4A w/ butterfly valves shown

## dimensions

2-1/2" - 6" type 1 & type 2 bypass

SIZE	2-1/2"	65 MM	3"	80MM	4"	100MM	6"	150MM
A (Butterfly Valves)	28	711	28.5	724	33	838	38.5	978
A (Gate Valves)	31	787	32	813	37.6	955	45.5	1156
B (Less Shut-off Valves)	16	406	16	406	19.8	503	24.5	622
C (Butterfly Valves - Type 1)	8.6	218	9.6	244	10.9	277	13	330
C (Butterfly Valves - Type 2)	13.3	338	13.3	338	12.1	307	13.8	351
C (NRS/PI Gate Valves - Type 1)	11.8	300	13	330	14	356	17.8	452
C (NRS/PI Gate Valves - Type 2)	13.3	338	13.3	338	14	356	17.8	452
C (OS&Y Open)	16.4	417	20.5	521	22.8	579	27.3	693
D (Centerline to Bottom)	3.9	99	3.9	99	4.6	117	5.9	150
E (Max w/Gate or Butterfly Valves - Type 1)	15.5	394	15.5	394	16.6	422	19.4	493
E (Max w/Gate or Butterfly Valves - Type 2)	14.1	358	14.1	358	17.4	442	18.4	467
F (Check Removal Clearance)	4.8	122	4.8	122	6.5	165	7.5	191
Test Cocks (NPT)	1/2"	15	1/2"	15	1/2"	15	3/4"	20
<b>WEIGHTS</b>	<b>LB.</b>	<b>KG</b>	<b>LB.</b>	<b>KG</b>	<b>LB.</b>	<b>KG</b>	<b>LB.</b>	<b>KG</b>
Net Wt. (Less Valves)	22	10	23	10	39	18	75	34
Net Wt. (w/ Butterfly Valves)**	96	44	102	46	128	58	189	86
Net Wt. (w/ NRS Gate Valves)**	94	43	109	49	149	68	273	124
Net Wt. (w/ OS&Y Gate Valves)**	109	49	125	57	180	82	333	151

notes:

nominal dimensions are shown. allowances must be made for manufacturers' tolerances.  
internal body connections are grooved on 2-1/2" - 10" sizes.

# DCDALF4A/DCDA2LF4A series

double check detector assembly

**lead free**

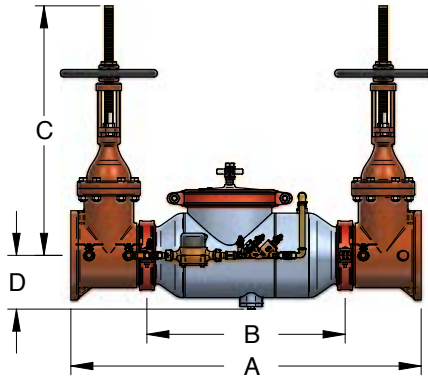

**type 1 bypass**  
8" DCDALF4A w/ OS&Y gates shown

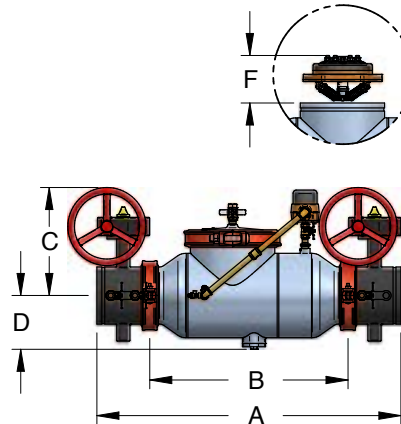

**type 2 bypass**  
8" DCDA2LF4A w/ butterfly valves shown

internal component  
removal space  
requirements

## dimensions

### 8" type 1 & type 2 bypass

SIZE	8"	200MM
A (Butterfly Valves)	46	1168
A (Gate Valves)	53.1	1349
B (Less Shut-off Valves)	30	762
C (Butterfly Valves - Type 1)	16.5	419
C (Butterfly Valves - Type 2)	16.5	419
C (NRS/PI Gate Valves - Type 1)	21	533
C (NRS/PI Gate Valves - Type 2)	21	533
C (OS&Y Open)	37.8	960
D (Centerline to Bottom)	8.3	211
E (Max w/Gate or Butterfly Valves - Type 1)	22.4	569
E (Max w/Gate or Butterfly Valves - Type 2)	22	559
F (Check Removal Clearance)	7.5	191
Test Cocks (NPT)	3/4"	20
WEIGHTS	LB.	KG
Net Wt. (Less Valves)	208	94
Net Wt. (w/ Butterfly Valves)**	399	181
Net Wt. (w/ NRS Gate Valves)**	540	245
Net Wt. (w/ OS&Y Gate Valves)**	615	279

notes:  
nominal dimensions are shown. allowances must be made for manufacturers' tolerances.  
internal body connections are grooved on 2-1/2" - 10" sizes.

# DCDALF4A/DCDA2LF4A series

double check detector assembly

**lead free**

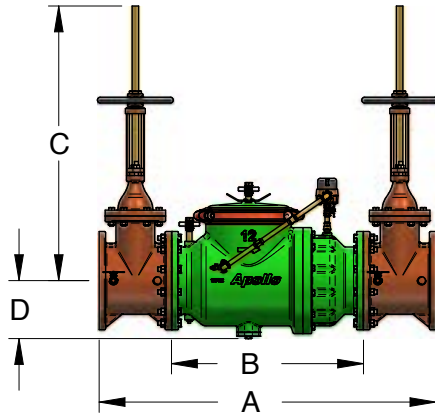
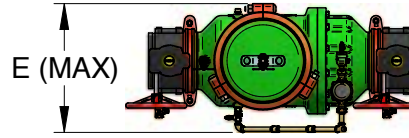
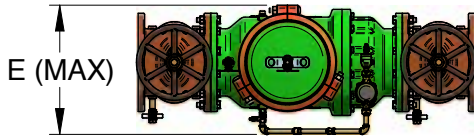

**type 2 bypass**  
12" DCDA2LF4A w/ OS&Y gates shown

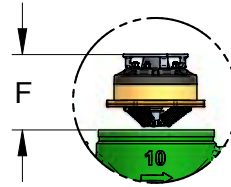

internal component  
removal space  
requirements

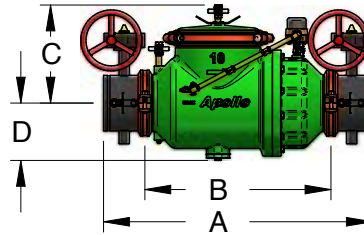

**type 2 bypass**  
10" DCDA2LF4A w/ butterfly valves shown

## dimensions

10" - 12" type 2 bypass

nominal dimensions are shown. allowances must be made for manufacturers' tolerances (3 1/8" (3 mm) per joint)

SIZE	10"	250MM	12"	300MM
A (Butterfly Valves)	52	1321	N/A	N/A
A (Gate Valves)	62.3	1582	65.4	1661
B (Less Shut-off Valves)	36	914	37	940
C (Butterfly Valves - Type 2)	19	483	N/A	N/A
C (NRS/PI Gate Valves - Type 2)	24.5	622	30	762
C (OS&Y Open)	45.8	1163	53.1	1349
D (Centerline to Bottom)	11.1	282	11.4	290
E (Max w/Gate or Butterfly Valves - Type 2)	24.9	632	25	635
F (Check Removal Clearance)	10	254	10	254
Test Cocks (NPT)	3/4"	20	3/4"	20
WEIGHTS	LB.	KG	LB.	KG
Net Wt. (Less Valves)	702	318	805	365
Net Wt. (w/ Butterfly Valves)**	985	447	N/A	N/A
Net Wt. (w/ NRS Gate Valves)**	1229	557	1685	764
Net Wt. (w/ OS&Y Gate Valves)**	1343	609	1800	816

notes:  
nominal dimensions are shown. allowances must be made for manufacturers' tolerances.  
internal body connections are flanged on 12" size.



# DCDALF4A/DCDA2LF4A series

double check detector assembly

**lead free**

## flow curves

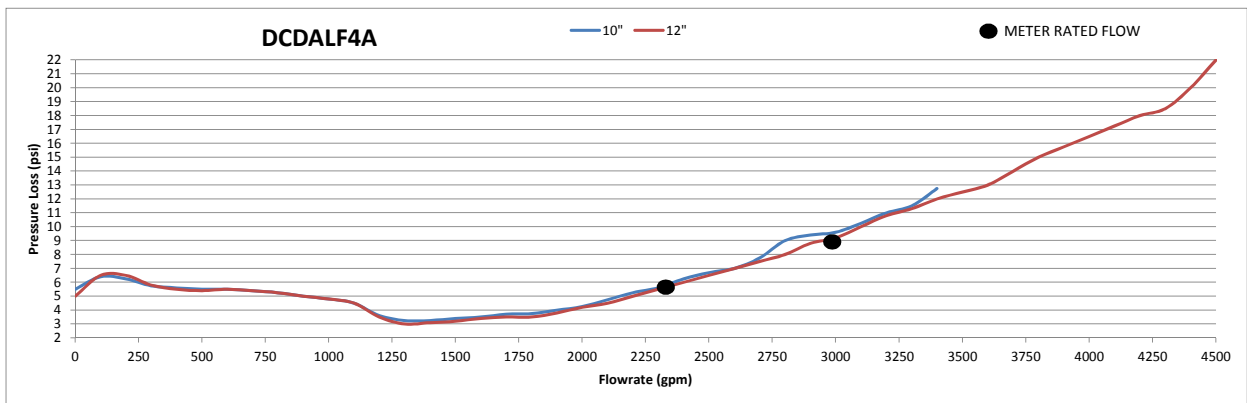
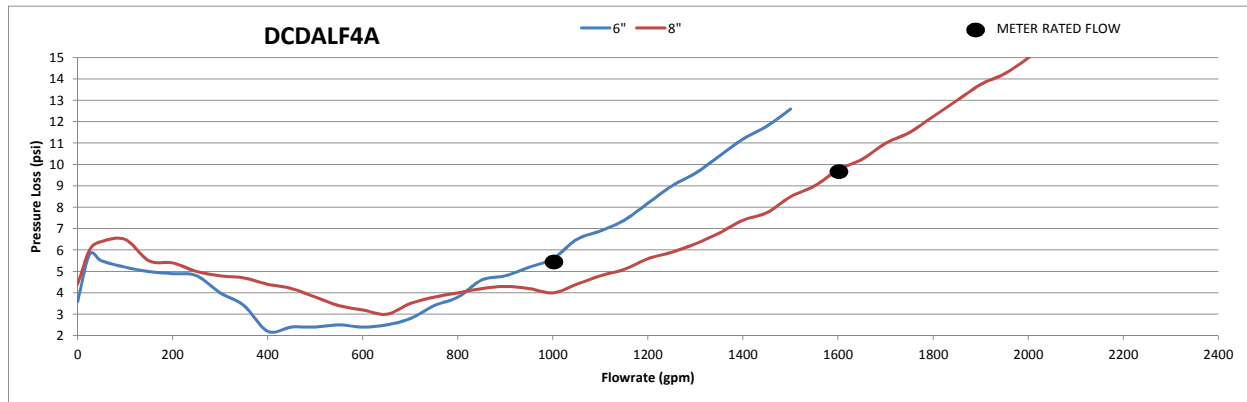
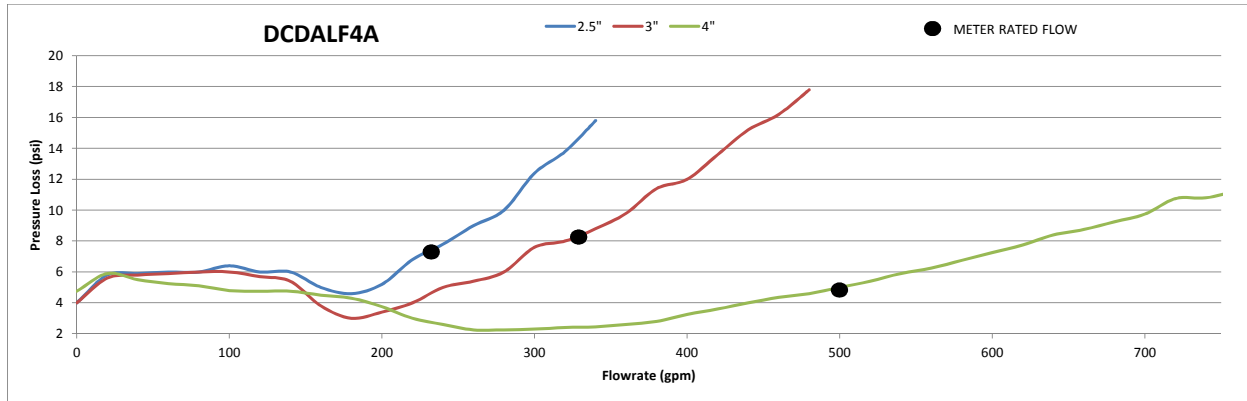

notes:  
 flow curves directly reflect data collected by an independent laboratory.  
 flow curves shown were recorded with gate shut-off valves. contact factory for more information.  
 all data points are based on ASSE increasing flow data, from zero GPM to rated flow (opening curve).  
 for high flow rates/pressure loss information - contact factory.