



Job Name:	
Job Location:	
Engineer:	
Contractor:	
Tag:	
PO#:	
Rep:	
Wholesale Dist.:	

DESCRIPTION

The Apollo lead free* Pressure Reducing Valve Model PRE (36ELF Series) is designed to conserve water and protect water distribution systems by automatically reducing elevated supply pressures. The dezincification resistant bronze body, stainless steel adjusting screw and dielectric polymer cage provide maximum corrosion resistance. Designed for easy in-line servicing with simple cartridge removal.

FEATURES

- Balanced Piston Design
- SS Adjusting Screw & Nut
- Sealed Cage for Vault Installations
- Built-in Thermal Expansion Bypass
- Large Area Integral Stainless Steel Strainer
- Modular Seat Disc and Strainer Cartridge
- Control Pressure Ranges:
15-75 psi and 75-150 psi
- Factory Tested and Preset at 60 psi
- High Flow / High Efficiency Design
- NPT, Solder, PEX, CPVC,
Push & Press Connections
- Single, Double & Less Union
Configurations Available
- 100% Manufactured in USA - ARRA Compliant**

PERFORMANCE RATING

- Maximum Supply Pressure: 400 psig
- Push & Press Max Supply Pressure: 200 psig
- Working Temperature Range: 33°F - 180°F

APPROVALS

- NSF/ANSI 372 Lead Free
- NSF/ANSI 61 Water Quality
- ASSE 1003
- IAPMO/UPC
- CSA B356

OPTIONS

- (-B) - Bronze Cap NEW!**
- (36E) - w/ Standard Materials for Non-Potable Applications
- Direct Press Connections, See Submittal SS1286
- Direct Push Connections, See Submittal SS1284

STANDARD MATERIALS LIST

BODY	LF Bronze, UNS 89836
UNION NUT	Brass, ASTM B16
TAILPIECE	LF Brass, UNS C27451
SCREEN	Stainless Steel
CAP	Noryl
DIAPHRAGM	NSF Grade EPDM
SEAT DISC	NSF Grade EPDM
ADJUSTING SCREW/NUT	Stainless Steel
SPRING	Stainless Steel, ASTM A228
O-RINGS	NSF Grade EPDM

DIMENSIONS

CONNECTION TYPE	SIZE (IN.)	DIMENSIONS (IN.)						WEIGHTS (LB.)	
		A	B	C	D	E	F	SINGLE UNION	DOUBLE UNION
Thread - FNPT	1/2	3.625	4.58	5.53	6	0.95	2.75	2.4	2.75
Solder		3.625	4.56	5.49	6	0.93	2.75	2.4	2.75
CPVC		3.625	4.33	5.03	6	0.70	2.75	2.4	2.75
PEX A		3.625	4.83	6.03	6	1.20	2.75	2.7	3.01
PEX B/C		3.625	4.65	5.67	6	1.02	2.75	2.7	2.99
Push		3.625	4.86	6.09	6	1.23	2.75	2.9	3.02
Push*		3.625	5.10	6.57	6	1.47	2.75	2.8	2.92
Press		3.625	4.62	5.61	6	0.99	2.75	2.9	3.02
Press*	3.625	4.97	6.31	6	1.34	2.75	2.4	2.75	
Thread - FNPT	3/4	3.625	4.56	5.49	6	0.93	2.75	2.4	2.75
Solder		3.625	4.56	5.49	6	0.93	2.75	2.4	2.75
CPVC		3.625	4.55	5.47	6	0.92	2.75	2.4	2.75
PEX A		3.625	4.83	6.03	6	1.20	2.75	2.7	3.02
PEX B/C		3.625	4.88	6.13	6	1.25	2.75	2.7	2.98
Push		3.625	5.41	7.19	6	1.78	2.75	2.9	3.02
Push*		3.625	5.23	6.83	6	1.60	2.75	2.8	3.23
Press		3.625	4.77	5.91	6	1.14	2.75	2.9	3.02
Press*	3.625	5.13	6.63	6	1.50	2.75	2.4	2.75	
Thread - FNPT	1	3.625	4.69	5.75	6	1.06	3.38	2.4	2.86
Solder		3.625	4.69	5.75	6	1.06	3.38	2.4	2.86
CPVC		3.625	4.79	5.95	6	1.16	3.38	2.4	2.86
PEX A		3.625	4.80	5.97	6	1.17	3.38	3.2	3.65
PEX B/C		3.625	5.18	6.73	6	1.55	3.38	3.1	3.56
Push		3.625	5.59	7.55	6	1.96	3.38	3.2	3.65
Push*		3.625	5.54	7.45	6	1.91	3.38	3.3	3.91
Press		3.625	4.81	5.99	6	1.18	3.38	3.2	3.65
Press*	3.625	5.25	6.87	6	1.62	3.38	2.4	2.86	

*Direct Connect

PEX A (ASTM F1960) - Cold Expansion PEX | PEX B/C (ASTM F1807) - Crimp Style PEX

*LEAD FREE: The wetted surfaces of this product shall contain no more than 0.25% lead by weighted average. Complies with Federal Public Law 111-380. ANSI 3rd party approved and listed.

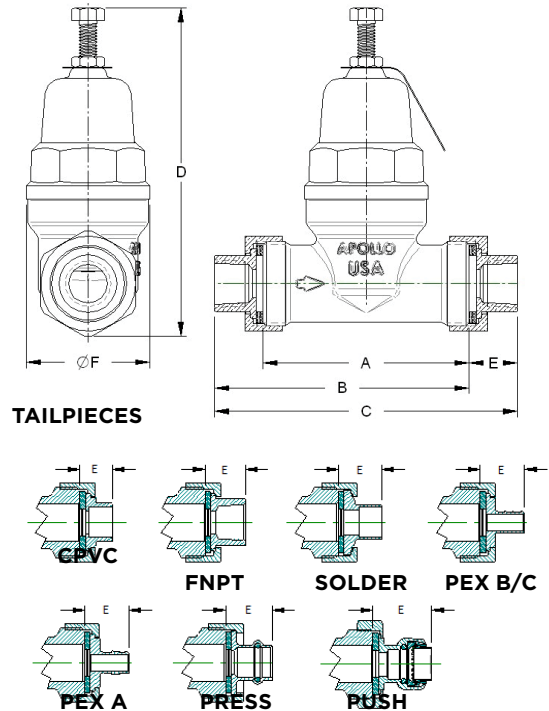

PART NUMBER MATRIX

36ELF 36E	1	X	X	XX	X	X
SERIES	STYLE	UNION	SIZE	PRESSURE RANGE	CONNECTION	OPTION
36ELF (LEAD FREE)	1	0 - NO UNION NPT	3 - 1/2"	01 - 15-75 PSIG RANGE	T - FNPT THREAD	B - BRONZE CAP
36E		1 - SINGLE UNION	4 - 3/4"	03 - 75-150 PSIG RANGE	S - SOLDER	
		2 - DOUBLE UNION	5 - 1"		C - CPVC	
					X - PEX B/C (F1807)	
					P - PUSH*	
					PR - PRESS**	
					X2 - PEX A (F1960)	

PEX A (ASTM F1960) - Cold Expansion PEX

PEX B/C (ASTM F1807) - Crimp Style PEX

* Available in Direct Connection, Single Union x NPT, and Double Union

** Available in Direct Connection, and Double Union

MODEL NUMBER MATRIX

PRE	X	X	X	X	LF
	UNION	PRESSURE RANGE	SIZE	END CONNECTION*	
	BLANK - SINGLE UNION	BLANK - 15-75 PSIG RANGE	12 - 1/2"	BLANK - FNPT X FNPT	
	D - DOUBLE UNION	H - 75-150 PSIG RANGE	34 - 3/4"	DIRECT CONNECT	
	T - NO UNION (THREADED ONLY)		1 - 1"	P - PUSH X PUSH PR - PRESS X PRESS	
				SINGLE UNION	
				C - CPVC X FNPT	
				P - PUSH X FNPT	
				S - SOLDER X FNPT	
				PR - PRESS X FNPT	
				X - PEX B/C (F1807) X FNPT	
				X2 - PEX A (F1960) X FNPT	
				DOUBLE UNION	
				C - CPVC X CPVC	
				CX - CPVC X PEX B/C	
				S - SOLDER X SOLDER	
				SC - SOLDER X CPVC	
				SX - SOLDER X PEX B/C	
				PR - PRESS X PRESS	
				X - PEX B/C X PEX B/C	
				X2 - PEX A X PEX A	

*Two letter union type offered in double union connection only.

Union connections are shipped loose.

PIPE SIZE	*FALLOFF (PSI)	PRESSURE DIFFERENTIAL (PSI)		
		25	50	75
WATER CAPACITY (GPM)				
1/2"	10	10	13	16
	15	13	18	22
	20	17	23	29
	30	22	29	36
3/4"	10	16	21	26
	15	20	27	32
	20	24	32	40
	30	29	38	48
1"	10	25	33	41
	15	30	42	52
	20	34	45	56
	30	35	47	59

FLOW CURVE

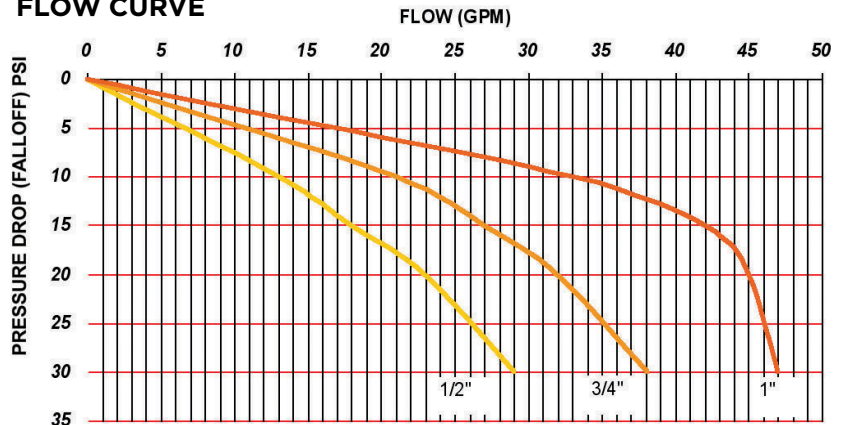

*Falloff is the difference between the PRV's set pressure and the flowing pressure at any given demand

Pressure Differential is the difference between the inlet supply pressure and the adjusted outlet pressure.

Pressure Falloff is the reduction in downstream pressure from the static (set) pressure as the flow increases through the valve.