



submittal sheet

# RPDALF4AN

Reduced Pressure Detector Assembly

## LEAD FREE



USC-FCCCHR



Job Name:	
Job Location:	
Engineer:	
Contractor:	
Tag:	
PO#:	
Rep:	
Wholesale Dist:	

### DESCRIPTION

The **2-1/2" - 12" Reduced Pressure Detector Assembly** shall be an Apollo® Model RPDALF4AN or RPDA2LF4AN. The assembly shall be manufactured in America and carry a 5-year Apollo® factory warranty. The normally vertical up / vertical down oriented body shall incorporate an internal swivel connection providing the ability to pivot the second check 180°, producing a vertical up RPDA assembly (2-1/2" - 8" only). The TriForce™ center-stem guided check valves shall feature reversible silicone rubber seat discs. The check valves shall be held in place by drop-in retainers (2 1/2" - 6") or SS studs & nuts (8" - 12"). Access to the check valves and relief valve internals shall be by an Apollo® quick-connect SS coupling (2-1/2" - 6") or grooved couplings (covers) and SS bolts (relief valves) (8" - 12"). The bodies shall be domestic SS in 2-1/2" - 8" sizes and FDA epoxy-coated ductile iron in 10" & 12" sizes. The assembly is a mainline RP with a Type 2 bypass consisting of a lead free\* single check (SCV) and meter bypassing the mainline second check to prevent backflow while accurately measuring all flows up to 2 gpm with the mainline 2nd check remaining closed. Assemblies with the optional Type 1 bypass consist of a lead free\* RP and meter which bypasses both mainline checks and accurately meters all flows up to 2 gpm with both mainline checks closed. The Apollo® domestic ball valve test cocks shall have SS handles. The assembly shall prevent contamination of the potable water supply due to back-siphonage or backpressure from substances that are health and non-health hazards. The pressure drop across the assembly shall be documented by an independent laboratory.

### FEATURES

- Domestic Stainless Steel Body: 2-1/2"-8"
- FDA Epoxy Coated Ductile Iron Body: 10" & 12"
- Easy Maintenance: No Special Tools Required
- Drop-In Check Retainers: 2-1/2"-6"
- Bolted-In Checks: 8"-12"
- Low Pressure Loss as Documented by an Independent Approval Laboratory
- Center Stem Guided TriForce™ Check Valves
- Modular Captured Spring Relief Valve
- Optional Air Gap Drains
- Small Installation Space Required - Small Footprint
- Approved for n-Flow and Vertical Up Flow
- Chloramine-Resistant Elastomers
- Made in the USA (D Option)
- Lead Free Standard
- Optional Valve Setters Eliminate Need for Thrust Blocks Below Grade
- US Patent Nos.: 6,443,184; 7,025,085; 7,533,699
- 5 Year Warranty
- Optional Mounting of Bypass on Either Side for Ease of Installation

### PERFORMANCE RATING

- Maximum Working Pressure: 175 psi
- Temperature Range: 33°F - 140°F, 180°F intermittent

### APPROVALS

- CSA B64.4
- Approved by the Foundation for Cross-Connection Control and Hydraulic Research at the University of Southern California (2-1/2" - 8" Type 1 Bypass, 10" - 12" Type 2 only)
- ASSE 1047 (with Meter)
- UL, ULC Classified
- FM Approved
- NSF/ANSI 372 Lead Free (2-1/2" - 12")

### STANDARD MATERIALS LIST

<b>BODY (2-1/2"-8")</b>	304 Stainless Steel
<b>BODY (10 &amp; 12")</b>	FDA Epoxy Coated Ductile Iron
<b>COVERS (2-1/2"-6")</b>	Glass Filled PPO/SS
<b>COVERS (8")</b>	304 Stainless Steel
<b>COVERS (10" &amp; 12")</b>	FDA Epoxy Coated Ductile Iron
<b>RELIEF VALVE</b>	Bronze (LF C89836)
<b>CHECK VALVES</b>	Bronze/Glass-Filled PPO/SS
<b>SPRINGS</b>	Stainless Steel
<b>SEAT DISCS</b>	Chloramine-Resistant Silicone

### PART NUMBER MATRIX

4ANLF	7 X	X	X	[X]	X
	BYPASS SUB-ASSEMBLY OPTIONS	SIZE	METER OPTION	SHUT-OFF VALVES (INLET X OUTLET)	OPTIONS
4ANLF - LEAD FREE (STANDARD)	0 - TYPE 1 W/ 1/2" REDUCED PRESSURE	9 - 2-1/2"	C - CUBIC FEET/MIN	3 - OS&Y FLANGE X OS&Y FLANGE	D - DOMESTIC ASSEMBLY
	2 - TYPE 2 W/1/2" SINGLE CHECK	0 - 3"	E - GALLONS/MIN	4 - OS&Y FLANGE X MONITORED (MON.) BUTTERFLY VALVE GROOVE†	
	3 - TYPE 1 W/ BYPASS ON LEFT*	A - 4"	G - LESS METER	6 - OS&Y FLANGE X POST INDICATOR FLANGE	
	4 - TYPE 2 W/ BYPASS ON LEFT*	C - 6"		7 - OS&Y FLANGE X OS&Y GROOVE	
		E - 8"		8 - OS&Y GROOVE X OS&Y GROOVE	
		G - 10"		9 - MON. BUTTERFLY VALVE GROOVE X MON. BUTTERFLY VALVE GROOVE†	
		H - 12"		10 - OS&Y FLANGE X POST INDICATOR GROOVE	
				13 - POST INDICATOR FLANGE X MON. BUTTERFLY VALVE GROOVE†	
				14 - POST INDICATOR FLANGE X POST INDICATOR FLANGE	
				16 - MON BUTTERFLY VALVE GROOVE X POST INDICATOR FLANGE†	
				17 - POST INDICATOR FLANGE X OS&Y GROOVE	
				18 - OS&Y GROOVE X POST INDICATOR GROOVE	

EXAMPLE: 4ANLF 70A E3 = 4" size Lead Free Reduced Pressure Detector Assembly with meter in GPM and OS&Y flanged inlet x OS&Y flanged outlet shut-off valves.

\*Orientation of bypass looking downstream. Standard is right hand side. Left hand is on opposite side  
†Butterfly valves not available in 12" size.

\*LEAD FREE: The wetted surfaces of this product shall contain no more than 0.25% lead by weighted average. Complies with Federal Public Law 111-380. ANSI 3rd party approved and listed.



submittal sheet

# RPDALF4AN

Reduced Pressure Detector Assembly

## LEAD FREE

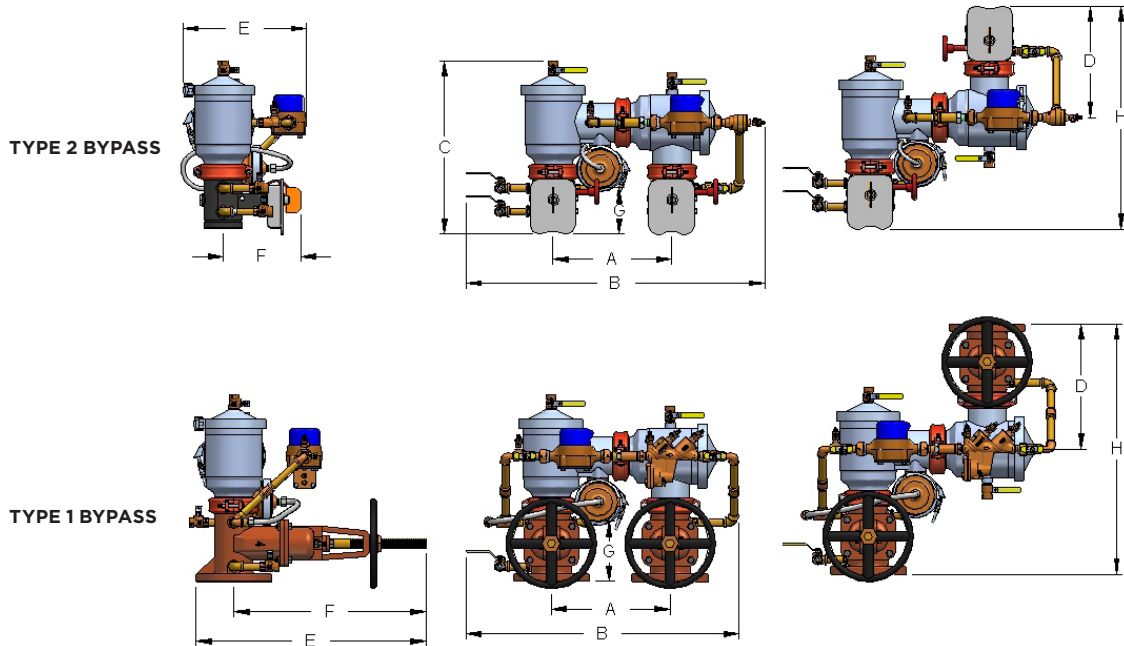

### DIMENSIONS

DIMENSIONS	2-1/2"	60MM	3"	75MM	4"	100MM	6"	150MM	8"	200MM	10"	250MM	12"	300MM
A (Centerline to Centerline)	12.5	318	12.5	318	14	356	16	406	18.5	470	21	533	26.8	681
B (Lay Length Space - Butterfly Valves)	32.8	833	32.8	833	35.5	902	40	1016	44	1118	54	1372	N/A	N/A
B (Lay Length Space - Gate Valves)	31	787	31	787	31.8	808	36.8	935	41.5	1054	49	1245	55.8	1417
C (Butterfly Valves - Flange to Top)	18.3	465	18.5	470	20	508	24.8	630	28.5	724	37	940	N/A	N/A
C (Gate Valves - Flange to Top)	19.6	498	20	508	22.5	572	27.8	706	32.1	815	40	1016	44	1118
D (Centerline to bottom Butterfly Valves)	11.5	292	11.8	300	13.3	338	15.6	396	17.9	455	19.8	503	N/A	N/A
D (Centerline to bottom Gate Valves)	13	330	13.5	343	14.9	378	18	457	21.4	544	24.8	630	28.8	732
E (Maximum Width - Butterfly Valves)	11.5	292	12.1	307	12.9	328	15.9	404	22.3	566	23.1	587	N/A	N/A
E (Maximum Width - NRS/PI Gate Valves)	15.6	396	16.9	429	18.6	472	23.8	605	29.1	739	36.3	922	40	1016
E (Maximum Width - OS&Y Valves Open)	22.7	575	24.2	614	26.6	679	34.4	875	44.9	1140	57.9	1471	61.9	1572
F (Centerline to Width - Butterfly Valves)	8	203	8.4	213	9	229	10.9	277	12.9	328	13.5	343	N/A	N/A
F (Centerline to Width - NRS/PI Gate Valves)	11.8	300	13	330	14	356	17.8	452	21	533	24.5	622	30	762
F (Centerline to Width - OS&Y Valves Open)	18.8	478	20.3	515	22.1	562	29.4	747	36.8	934	45.2	1147	52.2	1326
G (Relief Valve to SOV Flange - Butterfly Valves)	4.1	104	4.5	114	4.4	112	6.5	165	5.3	135	4	102	N/A	N/A
G (Relief Valve to SOV Flange - Gate Valves)	5.5	140	6	152	6	152	9	229	9	229	9	229	N/A	N/A
H (Flange to flange Vertical Up Butterfly Valves)	23	584	23.5	597	25	635	29	737	35.8	909	N/A	N/A	N/A	N/A
H (Flange to flange Vertical Up Gate Valves)	26	660	27	686	29.8	757	36	914	42.8	1087	N/A	N/A	N/A	N/A
I (Check Removal Clearance)	6	152	6	152	6	152	8	203	8.5	216	12	305	12	305
Test Cocks (NPT)	1/2"	13	1/2"	13	1/2"	13	3/4"	20	3/4"	20	3/4"	20	3/4"	20
<b>WEIGHTS</b>	<b>LB.</b>	<b>KG</b>	<b>LB.</b>	<b>KG</b>	<b>LB.</b>	<b>KG</b>	<b>LB.</b>	<b>KG</b>	<b>LB.</b>	<b>KG</b>	<b>LB.</b>	<b>KG</b>	<b>LB.</b>	<b>KG</b>
Net Wt. (W/ Butterfly Valves)	85	39	88	40	92	42	151	69	456	207	1039	472	N/A	N/A
Ship Wt. (W/ Butterfly Valves)	146	66	149	68	153	70	231	105	591	269	1229	559	N/A	N/A
Net Wt. (W/ NRS/Post Indicator Valves)	112	51	129	59	155	70	266	121	642	292	1368	622	1847	840
Ship Wt. (W/ NRS/Post Indicator Valves)	173	79	190	86	216	98	346	157	777	353	1558	708	2137	971
Net Wt. (W/ OS&Y Valves)	130	59	142	65	186	85	326	148	717	326	1483	674	1962	892
Ship Wt. (W/ OS&Y Valves)	191	87	203	92	247	112	406	185	852	387	1673	760	2152	978

Nominal dimensions are shown. Allowances must be made for manufacturers' tolerances ( $\pm 1/8"$  (3 mm) per joint)  
 Internal body connections are grooved on 2-1/2" to 10" sizes.  
 Internal body connections are flanged on 12" size.

704.841.6000  
 apollovalves.com

SS1331 © 04/22 Page 2 of 4

This specification is provided for reference only. Apollo reserves the right to change any portion of this specification without notice and without incurring obligation to make such changes to Apollo products previously or subsequently sold. Most current information available at apollovalves.com.





submittal sheet

# RPDALF4AN

Reduced Pressure Detector Assembly

## LEAD FREE

### FLOW CURVES

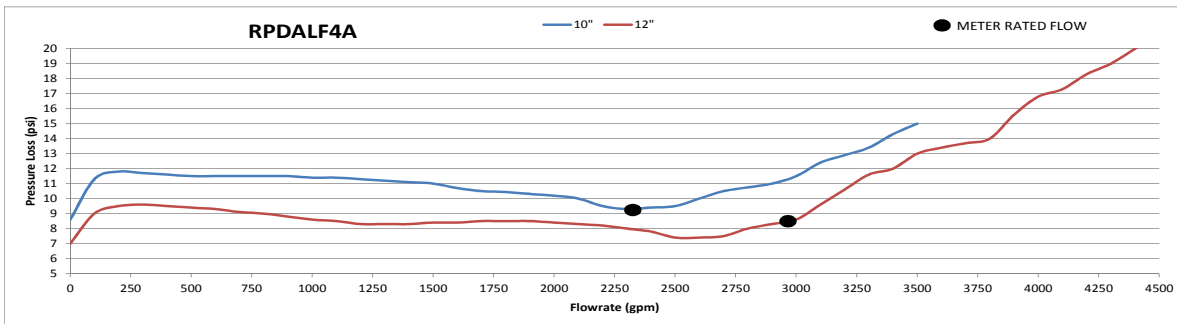
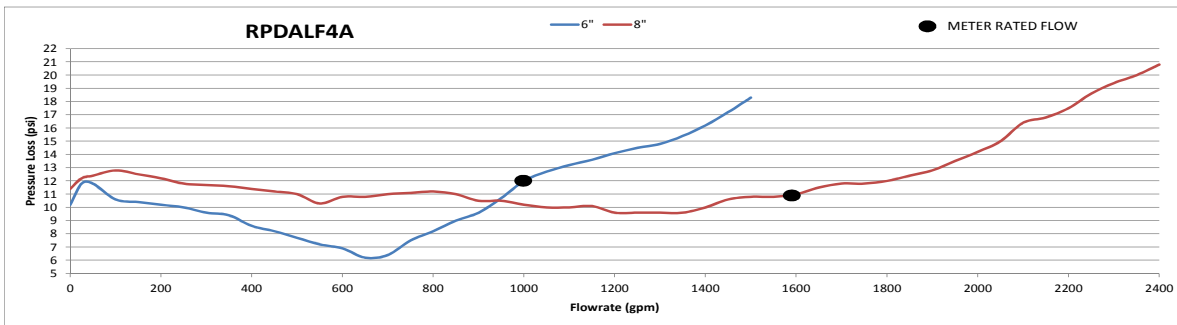
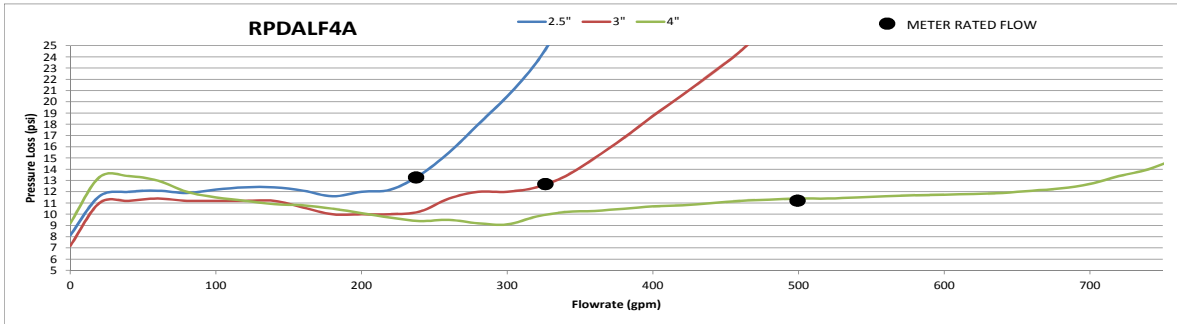

Notes:  
 Flow curves directly reflect data collected by an independent laboratory.  
 Flow curves shown were recorded with gate shut-off valves. Contact factory for more information.  
 All data points are based on ASSE increasing flow data, from zero GPM to rated flow (opening curve).  
 For high flow rates/pressure loss information – contact factory.



submittal  
sheet

# RPDALF4AN

Reduced Pressure Detector Assembly

## LEAD FREE

**OPTIONAL VALVE SETTERS - ORDERED SEPARATELY**  
(See SS1174 Submittal Sheet for details)

**FACTORY CODE**

4AN	- 00X	- X
	SIZE	TYPE
4AN	9 - 2-1/2"	F - FLANGE X FLANGE (2 1/2" - 12")
	0 - 3"	MJF - MECHANICAL JOINT X FLANGE (3" - 8")
	A - 4"	MJ - MECH. JOINT X MECH. JOINT (3" - 8")
	C - 6"	
	E - 8"	
	G - 10"	
	H - 12"	

