

- 10) Complete the fastener torquing sequence with one final check going around the bolt pattern clockwise at the specified torque level.
- 11) Tighten the stem packing adjustment screws to the values shown in Table 2. Do not over-tighten the stem packing adjustment screws.
- 12) Complete the re-assembly by installing the lever, lock plate and stops or actuator as applicable.

**Table 2: Torque Requirements**

Valve Size	Gland Nut Torque (+ or - 10%) in-lb (ft-lb)	Gland Plate Fastener Torque (+ or - 10%) in-lb (ft-lb)	Body Bolt Torque (+ or - 10%) in-lb (ft-lb)
1/4	96 (8)	N/A	96 (8)
3/8	96 (8)	N/A	96 (8)
1/2	156 (13)	N/A	96 (8)
3/4	156 (13)	N/A	96 (8)
1	516 (43)	N/A	96 (8)
1-1/4	516 (43)	N/A	156 (13)
1-1/2	516 (43)	N/A	156 (13)
2	516 (43)	N/A	276 (23)
2-1/2	996 (83)	N/A	540 (45)
3	N/A	156 (13)	900 (75)
4	N/A	156 (13)	2400 (200)



A Division of Conbraco Industries, Inc. Matthews, NC Pageland, SC Conway, SC

## 82/82A SERIES INSTALLATION, OPERATION & MAINTENANCE MANUAL

### PARTS ILLUSTRATION

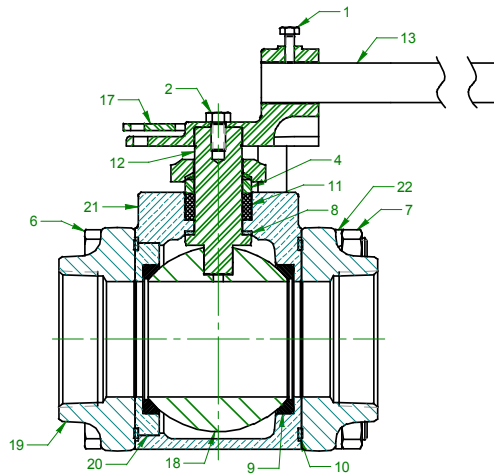

NO.	NAME	NO.	NAME	NO.	NAME
1	HANDLE SCREW	9	SEAT	16	STOP
2	ADPT SCREW	10	BODY SEAL	17	LOCKPLATE
3	STOP SCREW	11	STEM PACKING	18	BALL
4	PACKING GLAND	12	STEM	19	END CAP
5	GLAND SCREW	13	HANDLE	20	SEAT HOLDER
6	BODY BOLT	14	HANDLE ADPT	21	BODY
7	NUT	15	GLAND PLATE	22	LOCK WASHER
8	STEM BEARING				

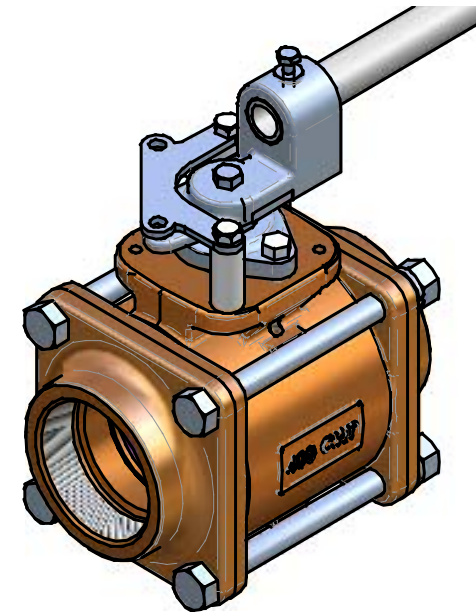

## **INSTALLATION**

The Apollo 82/82A Series Ball valves are bi-directional. They may be installed in vertical or horizontal pipe runs without regard to flow direction or stem orientation.

Note: Valves must be installed in piping systems that comply with the applicable portions the ASME B31 standards. Special considerations must be taken with respect to pipe line expansions and contractions and the media expansion and contractions within the piping system.

### **Threaded End Valves**

Pipe connection to be threaded into these valves should be accurately threaded, clean and free of foreign material or metal shavings. PTFE pipe tape is recommended for use as the pipe joint sealant. Two wrenches must be used when making up pipe joints to these valves. Apply one wrench on the valve end closest to the pipe joint being tightened and the other wrench to the pipe to prevent transmitting torque through the valve body joint. Typical pipe make-up is 1-1/2 turns after installing the pipe hand-tight.

### **Solder End (Sweat In) Valves**

*Caution: 82/82A series valves must be partially disassembled before soldering in line. Damage to seats and seals is likely without partial disassembly.*

Begin by placing the valve in the open position and loosening the four body bolts. Complete removal of one bolt is required. Next, remove the center section subassembly and set aside. Protect seat and seal surfaces from damage.

Carefully, solder the end caps in line. Overheating bronze end caps can cause permanent damage. Protect the end cap faces from damage during soldering.

Once the end caps have completely cooled to the touch, reinstall the center section subassembly. Valves 2" and smaller are shipped with an extra set of seats. Replace the used seats prior to reassembly. Install the body bolts and hand-tighten all four hex nuts. Using a criss-cross pattern, in three approximately equal steps, torque the body bolts to the value given in Table 2. Cycle the valve open and closed between each step to assure continued smooth operation. Complete the fastener torquing sequence with one final check going around the bolt pattern clockwise at the specified torque level.

## **OPERATION**

The valve handle is marked showing proper rotation direction for "ON" and "OFF" positions. Rotation is clockwise for "OFF" (closed) and counterclockwise for "ON" (open).

## **MAINTENANCE**

### **Regular Maintenance**

Normal stem packing wear can be compensated for by adjusting the packing gland nut (1/4" thru 2-1/2" valves) or gland plate fasteners (3" & 4" valves). The handle may need to be removed for easy access to the packing gland nut. Wrench part number H371400 is available to ease this operation. Tighten the packing gland nut or gland plate fasteners clockwise in 1/8 turn increments until observed leakage stops. Do not exceed the torque levels shown in Table 2. Reinstall the handle if necessary.

### **Major Overhaul**

Due to the uncomplicated design of the 82/82A series, these valves can easily be rebuilt. Repair kits are available and can be purchased through your local distributor. These kits typically contain a complete set of seats and seals. Complete center sections are also available.

**Table 1: Repair Kits**

Valve Size	Kit Number (RPTFE)	Valve Size	Kit Number (RPTFE)
1/4" & 3/8"	8200201	1-1/2"	8200701
1/2"	8200301	2"	8200801
3/4"	8200401	2-1/2"	8200901
1"	8200501	3"	82A00001
1-1/4"	8200601	4"	82A00A01

### **Disassembly**

- 1) After de-pressurizing the system, operate the valve fully open to fully closed to assure there are no trapped fluids or pressure in the body cavity. Return the valve to the open position for disassembly.
- 2) Begin disassembly by loosening the body bolts. Complete removal of one bolt is required for center section removal.
- 3) Remove the center section from the piping system. It may be necessary to spread the end caps slightly to overcome compressive loads imparted by the piping system.
- 4) After removing the center section from the piping system, rotate the handle to the closed position for ball and seat removal. Carefully press the spherical surface of the ball by hand for removal of the first seat. Press in the opposite direction to remove the other seat.
- 5) If ball inspection reveals scars or other damage, it is recommended that the complete center section be replaced.
- 6) If no ball damage is found, continue the rebuild process by removing the handle. The packing gland nut or gland plate, packing gland and fasteners should also be removed.
- 7) Press the stem downward into the body to facilitate removal of the stem, stem bearing and stem packing. Do not damage sealing surfaces when removing the stem.
- 8) Finally, remove the stem packing. Do not scratch or scar the packing box.

### **Re-Assembly**

- 1) Begin the re-assembly process by cleaning each of the component parts with a clean towel or cloth.
- 2) Place the new stem bearing on the stem, and insert the stem into the valve body stem bore. Place the flats on top of the stem perpendicular to the centerline of the body.
- 3) Install the stem packing, packing gland nut, or packing gland, gland plate, and fasteners as required. Tighten finger tight only at this time.
- 4) Carefully insert the ball into the body. Rotate the stem to the open position.
- 5) Apply a small amount of service compatible lubricant to the new seats and install them in the valve body. Seats may be installed dry however some assembly lubricant is desirable and acts to hold the seats in place during the assembly process.
- 6) Install the body seal on valves 2-1/2" and larger.
- 7) Slip the body subassembly into the end caps installed in the pipeline. Lubricate and install the body bolts and nuts finger tight at this time.
- 8) Cycle the valve open and closed several times to assure all components are properly aligned.
- 9) Using a criss-cross pattern, in three approximately equal steps, torque the body bolts to the value given in Table 2. Cycle the valve open and closed between each step to assure continued smooth operation.