



88B-100 SERIES

CARBON STEEL ASME CLASS 150 FLANGED STD. PORT BALL VALVE
3"



FOR STANDARDS COMPLIANCE AND STANDARD FEATURES REFER TO PAGE D-3.

STANDARD MATERIAL LIST

	PART	MATERIAL
1	Body	ASTM A216-WCB
2	Retainer	ASTM A108 Type 1215
3	Ball	ASTM A108 Type 1215 Chrome Plated
4	Stem	ASTM A108 Type 1215 Chrome Plated
5	Packing Gland	ASTM A108 Type 1215
6	Stem Seals	PTFE
7	Seats	TFM 1700
8	Gland Screws	ASTM A193 B7
9	Gland Plate	316 Stainless Steel
10	Stem Nut	18-8 Stainless Steel
11	Lever	316 Stainless Steel with Vinyl Grip
12	Stem Bearing	RPTFE
13	Stop	ASTM A108 Type 1215
14	Stop Screw	SAE J429 Grade 2
15	Lock Plate	ASTM A366 Steel
16	Body Seal	RPTFE
17	Grounding Spring	Stainless Steel
18	Lockwasher	302 or 304 Stainless Steel

VARIATIONS AVAILABLE

- 88B-130 Series (Ni-Cu Ball & Stem)
- 88B-140 Series (316 Stainless Steel Ball & Stem)

OPTIONS AVAILABLE

(MORE INFORMATION IN SECTION J)

- Minimum quantities apply.
- To specify an option, replace the "01" standard suffix with the suffix of the option.
- To specify multiple options, replace the "01" suffix with the desired suffixes in the numerical order shown below. NOTE: Not all suffixes can be combined together.

(SUFFIX)	OPTION
-01	Standard Configuration
-04-	2-1/4" Stem Extension (Carbon Steel, Zinc Plated)
-14-	Side Vented Ball (Uni-Directional). Not Available with Plated CS Ball
-21-	UHMWPE Seats
-24-	Graphite Packing, Spiral Wound Graphite Body Seal, RPTFE Bearing (API 607, 6th Edition, ISO 10497:2010)
-26-	Chlorine Service. Vented. Special Cleaning. Assembled Dry. (for CS, Hastelloy and Ni-Cu Valves. Ball Must be Hastelloy or Ni-CU)
-35-	PTFE Seats and Seals
-38-	PEEK Seats and Graphite Packing (3" Only)
-49-	No Lubrication. Assembled Dry
-65-	MPTFE Seats and Graphite Packing (Fire Safe)
-67-	Cleaned for Industrial Gases
-69-	Drilled and Tapped Purge Ports with Plugs
-70-	4" Extended Bonnet
-76-	Live Loaded (Lever)
-77-	Live Loaded (Gear, Actuator)
-80-	TFM 1600 Seats, PTFE Chevron Packing, RPTFE Body Seal, PEEK Bearing
-82-	Flat Face Flanges
-90-	Double Packed 4" Extended Bonnet
-9P-	Double Packed 4" Extended Bonnet with Monitoring Port
-CE-	CE Marking. See Page D-3 "Product Approvals" for Availability
-EF-	Graphite Packing (API 641 Compliant)
-EP-	Garlock EVSP Stem Packing with Spiral Wound Graphite Gasket (Fire Safe by Design)
-KF-	PCTFE Stem Bearing
-MG-	Gear Operator with Standard Handwheel
-MH-	Gear Operator with Standard Handwheel & Locking Device
-MJ-	Gear Operator with Oversize Handwheel
-MK-	Gear Operator with Oversize Handwheel & Locking Device
-TC-	With Test Certificate
-TD-	Tested to API Spec 6D
-UA-	AIS (American Iron & Steel) Compliant
-UL-	UL & CSA Listed (with Markings)
-ZP1-	Fugitive Emissions Packing (Viton)
-ZP2-	Fugitive Emissions Packing (Buna-N)
-ZP3-	Fugitive Emissions Packing (Kalrez)

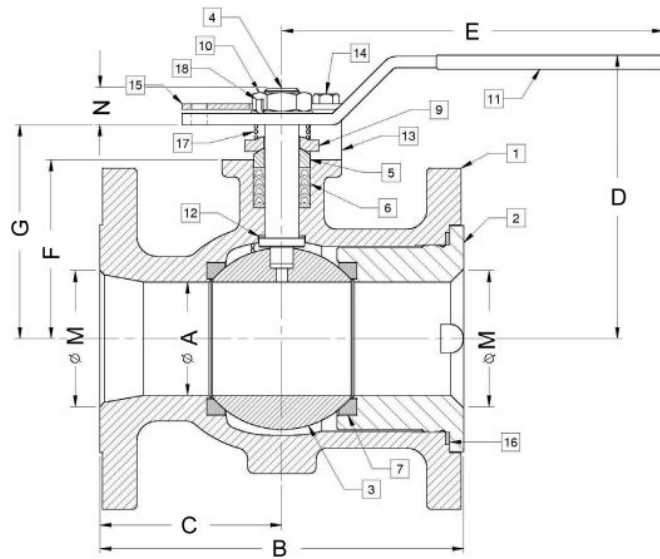

ACTUATOR MOUNTING

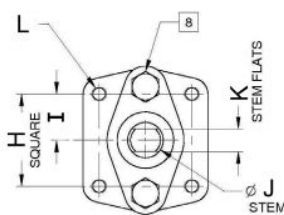

Pressure/Temperature Ratings - Page M-9, Graph No. 1

DIMENSIONS

PART NO.	SIZE	A	B	C	D	E	F	G	H	I	J	K	L	M	N	WT.
88B-100-01	3"	2.50	8.00	4.00	6.23	8.40	3.93	4.70	1.949	0.974	0.750	0.477	5/16-18	3.00	0.77	43

REV. 02DEC24

88B-100 SERIES

CARBON STEEL ASME CLASS 150 FLANGED STD. PORT BALL VALVE
4" THRU 10" SHORT PATTERN



FOR STANDARDS COMPLIANCE AND STANDARD FEATURES REFER TO PAGE D-3.

STANDARD MATERIAL LIST

PART	MATERIAL	
1	Body	ASTM A216-WCB
2	Retainer	ASTM A108 Type 1215
3	Ball	ASTM A108 Type 1215 (Chrome Plate)
4	Stem	ASTM A108 Type 1215 (Chrome Plate)
5	Packing Gland	ASTM A108 Type 1215
6	Stem Seals	PTFE
7	Seats	TFM 1700
8	Gland Screws	ASTM A193 B7
9	Gland Plate	316 Stainless Steel
10	Adapter Screw	18-8 Stainless Steel
11	Handle Adapter	316 Stainless Steel
12	Stem Bearing	RPTFE
13	Stop	ASTM A108 Type 1215
14	Stop Screw	SAE J429 Grade 2
15	Lock Plate	ASTM A366 Stainless Steel
16	Body Seal	RPTFE
17	Lockwasher	302 or 304 Stainless Steel
18	Grounding Spring	Stainless Steel
19	Adapter Screw	18-8 Stainless Steel
20	Pipe Handle	Galvanized Steel (not shown)

VARIATIONS AVAILABLE

- 88B-130 Series (Ni-Cu Ball & Stem)
- 88B-140 Series (316 Stainless Steel Ball & Stem)

OPTIONS AVAILABLE

(MORE INFORMATION IN SECTION J)

- Minimum quantities apply.
- To specify an option, replace the "01" standard suffix with the suffix of the option.
- To specify multiple options, replace the "01" suffix with the desired suffixes in the numerical order shown below. NOTE: Not all suffixes can be combined together.

(SUFFIX)	OPTION
-01	Standard Configuration
-14-	Side Vented Ball (Uni-Directional). Not Available with Plated CS Ball
-21-	UHMWPE Seats
-24-	Graphite Packing, Spiral Wound Graphite Body Seal, RPTFE Bearing (API 607, 6th Edition, ISO 10497:2010)
-26-	Chlorine Service. Vented. Special Cleaning. Assembled Dry. (for CS, Hastelloy and Ni-Cu Valves. Ball Must be Hastelloy or Ni-Cu)
-35-	PTFE Seats and Seals
-38-	PEEK Seats and Graphite Packing
-49-	No Lubrication. Assembled Dry
-65-	MPTFE Seats and Graphite Packing (Fire Safe)
-67-	Cleaned for Industrial Gases
-69-	Drilled and Tapped Purge Ports with Plugs
-70-	4" Extended Bonnet
-76-	Live Loaded (Lever)
-77-	Live Loaded (Gear, Actuator)
-80-	TFM 1600 Seats, PTFE Chevron Packing, Spiral Wound PTFE Body Seal, PEEK Bearing
-82-	Flat Face Flanges
-90-	Double Packed 4" Extended Bonnet
-9P-	Double Packed 4" Extended Bonnet with Monitoring Port
-CE-	CE Marking. See Page D-3 "Product Approvals" for Availability
-EF-	Graphite Packing (API 641 Compliant)
-EP-	Garlock EVSP Stem Packing with Spiral Wound Graphite Gasket (Fire Safe by Design)
-KF-	PCTFE Stem Bearing
-MG-	Gear Operator with Standard Handwheel
-MH-	Gear Operator with Standard Handwheel & Locking Device
-MJ-	Gear Operator with Oversize Handwheel
-MK-	Gear Operator with Oversize Handwheel & Locking Device
-TC-	With Test Certificate
-TD-	Tested to API Spec 6D
-UA-	AIS (American Iron & Steel) Compliant
-UL-	UL & CSA Listed (with Markings)
-ZP1-	Fugitive Emissions Packing (Viton)
-ZP2-	Fugitive Emissions Packing (Buna-N)
-ZP3-	Fugitive Emissions Packing (Kalrez)

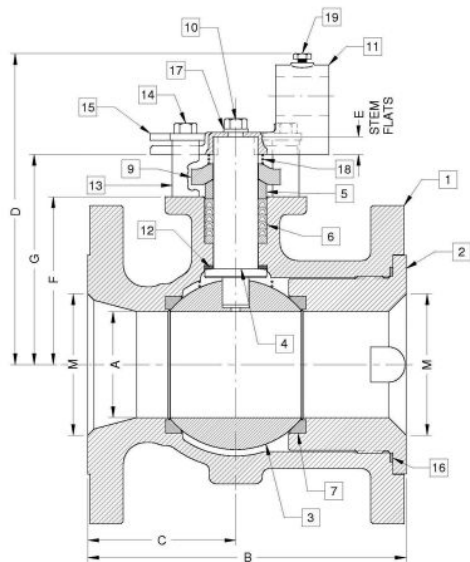

ACTUATOR MOUNTING

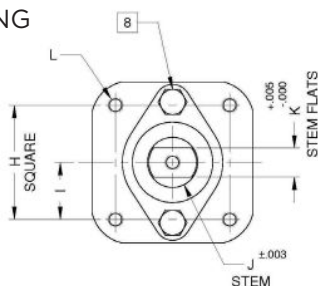

DIMENSIONS

PART NO.	SIZE	A	B	C	D	E	F	G	H	I	J	K	L	M	WT.
88B-10A-01	4"	3.00	9.00	4.18	8.80	0.50	4.75	5.95	2.840	1.420	1.250	0.725	3/8-16	4.00	72
88B-10C-01	6"	4.00	10.50	5.25	9.99	0.50	5.94	7.13	2.840	1.420	1.250	0.725	3/8-16	6.00	110
88B-10E-01	8"	6.00	11.50	5.75	13.61	1.00	7.63	9.36	4.596	2.298	2.000	1.375	3/4-10	8.00	210
88B-10G-01	10"	8.00	13.00	6.50	N/A	1.00	9.50	11.23	4.596	2.298	2.000	1.375	3/4-10	10.0	350

REV. 02DEC24

Pressure/Temperature Ratings - Page M-9, Graph No. 1



FLOW DATA

FLOW DATA

The listed C_v “factors” are derived from actual flow testing, at Apollo’s Pageland, South Carolina factory. These tests were completed using standard “off the shelf” valves with no special preparation and utilizing standard schedule 40 pipe. It should be understood that these factors are for the valve only and also include the connection configuration. The flow testing is done utilizing water as a fluid media and is a direct statement of the gallons of water flowed per minute with a 1 psig pressure differential across the valve/connection unit. Line pressure is not a factor. Because the C_v is a factor, the formula can be used to estimate flow of most media for valve sizing.

FLOW OF LIQUID

$$Q = C_v \sqrt{\frac{\Delta P}{SpGr}}$$

$$\text{or } \Delta P = \frac{(Q)^2 (SpGr)}{(C_v)^2}$$

WHERE:

- Q = Flow in US gpm
- ΔP = Pressure drop (psig)
- SpGr = Specific gravity at flowing temperature
- C_v = Valve constant

FLOW OF GAS

$$Q = 1360 C_v \sqrt{\frac{(\Delta P) (P_2)}{(SpGr) (T)}}$$

$$\text{or } \Delta P = \frac{5.4 \times 10^{-7} (SpGr) (T) (Q)^2}{(C_v)^2 (P_2)}$$

WHERE:

- Q = Flow in SCFH
- ΔP = Pressure drop (psig)
- SpGr = Specific gravity (based on air = 1.0)
- P2 = Outlet pressure-psia (psig + 14.7)
- T = (temp. °F + 460)
- C_v = Valve constant

CAUTION: The gas equation shown, is valid at very low pressure drop ratios. The gas equation is NOT valid when the ratio of pressure drop (ΔP) to inlet pressure (P1) exceeds 0.02.

NOTE: Only use the gas equation shown if (P1-P2)/P1 is less than 0.02.

CV FACTORS FOR APOLLO VALVES (CONTINUED ON M-4)

VALVE	SIZE (IN.)														
	1/4	3/8	1/2	3/4	1	1.25	1.5	2	2.5	3	4	6	8	10	12
70B-140 Series	8.4	7.2	15	30	43	48	84	108	190	370	670	--	--	--	--
70-100/200 Series	8.4	7.2	15	30	43	48	84	108	190	370	670	--	--	--	--
70-300/400 Series	--	--	15	30	43	48	84	108	--	--	--	--	--	--	--
70-600 Series	2.3	4.5	5.4	12	14	21	34	47	--	--	--	--	--	--	--
70-800 Series	8.4	7.2	15	30	43	48	84	--	--	--	--	--	--	--	--
71-AR Series	--	--	--	30	43	48	84	108	190	370	--	--	--	--	--
71-100/200 Series	--	--	--	30	43	48	84	108	190	370	--	--	--	--	--
72-100/900 Series	--	--	26	48	65	125	170	216	--	--	--	--	--	--	--
72-1xx-A/72-9xx-A Series	--	--	26	48	65	125	170	245	--	--	--	--	--	--	--
73A-100 Series	8.4	7.2	15	30	43	48	84	108	--	--	--	--	--	--	--
73-300/400 Series	--	--	26	48	65	125	170	216	--	--	--	--	--	--	--
74-100 Series	8.4	7.2	15	30	43	48	84	108	190	370	670	--	--	--	--
75-100 Series	8.4	7.2	15	30	43	48	84	108	190	370	670	--	--	--	--
76-AR Series	8.4	7.2	15	30	43	48	84	108	190	370	670	--	--	--	--
76F-100 Series	8.1	15	15	51	68	125	177	389	--	--	--	--	--	--	--
76FJ-100 Series	8.1	15	15	51	68	125	177	389	--	--	--	--	--	--	--
76FK-100 Series	8.1	15	15	51	68	125	177	389	--	--	--	--	--	--	--
76-100 Series	8.4	7.2	15	30	43	48	84	108	190	370	--	--	--	--	--
76-300/400 Series	--	--	26	48	65	125	170	216	--	--	--	--	--	--	--
76-600 Series	2.3	4.5	5.4	12	14	21	34	47	--	--	--	--	--	--	--
76J-100 Series	8.4	7.2	15	30	43	48	84	108	190	370	--	--	--	--	--
76J-AR Series	8.4	7.2	15	30	43	48	84	108	190	370	670	--	--	--	--
76K-100 Series	8.4	7.2	15	30	43	48	84	108	190	370	--	--	--	--	--
76K-AR Series	8.4	7.2	15	30	43	48	84	108	190	370	670	--	--	--	--
7K-100 Series	--	--	15	51	68	125	177	389	503	--	--	--	--	--	--
77-AR Series	8.1	15	15	51	68	--	177	389	--	--	--	--	--	--	--

REV. 02DEC24



FLOW DATA

FOR APOLLO BALL VALVES

CV FACTORS FOR APOLLO VALVES (CONTINUED FROM M-3)

VALVE	SIZE (IN.)														
	1/4	3/8	1/2	3/4	1	1.25	1.5	2	2.5	3	4	6	8	10	12
77C-100/200 Series	4.5	7.2	16	36	68	125	177	389	503	--	--	--	--	--	--
77D-140 Series	4.5	7.2	16	36	68	125	177	389	--	--	--	--	--	--	--
77D-640 Series	--	--	--	11	24	35	--	--	--	--	--	--	--	--	--
77G-UL Series	4.5	7.2	16	36	68	125	177	389	503	--	--	--	--	--	--
77W Series	--	--	16	36	68	125	177	389	--	--	--	--	--	--	--
77-100/200 Series	8.1	15	15	51	68	125	177	389	503	--	--	--	--	--	--
79 Series	8.5	8.5	9.8	32	44	66	148	218	440	390	--	--	--	--	--
80 Series	8.4	7.2	15	30	43	48	84	108	190	370	--	--	--	--	--
82-100/200 Series	8.1	14	26	51	68	120	170	376	510	996	1893	--	--	--	--
83A/83B Series	8.1	14	26	51	68	120	170	376	--	--	--	--	--	--	--
83R-100/200 Series	--	--	--	--	--	--	170	376	--	996	1893	--	--	--	--
86A/86B Series	8.1	14	26	51	68	120	170	376	--	--	--	--	--	--	--
86R-100/200 Series	--	--	--	--	--	--	170	376	--	996	1893	--	--	--	--
87A-100 Series	--	--	--	--	--	--	86	104	234	375	673	1099	1902	3890	--
87A-200 Series	--	--	15	19	75	--	195	410	545	1021	2016	4837	9250	15170	22390
87A-700 Series	--	--	--	--	--	--	86	104	234	375	673	1099	1902	3890	--
87A-900 Series	--	--	15	19	75	--	195	410	545	1021	2016	4837	9250	15170	22390
87A-F00 Series	--	--	--	--	75	--	195	410	545	1021	2016	4837	--	--	--
87B-100 Series	--	--	--	--	--	--	--	--	375	673	1099	1902	3890	--	--
87J-100 Series	--	--	--	--	--	--	86	104	234	375	673	1099	1902	3890	--
87J-200 Series	--	--	15	19	75	--	195	410	545	1021	2016	4837	9250	15170	22390
87J-700 Series	--	--	--	--	--	--	86	104	234	375	673	1099	1902	3890	--
87J-900 Series	--	--	15	19	75	--	195	410	545	1021	2016	4837	9250	15170	22390
87K-100 Series	--	--	--	--	--	--	86	104	234	375	673	1099	1902	3890	--
87K-200 Series	--	--	15	19	75	--	195	410	545	1021	2016	4837	9250	15170	22390
87K-700 Series	--	--	--	--	--	--	86	104	234	375	673	1099	1902	3890	--
87K-900 Series	--	--	15	19	75	--	195	410	545	1021	2016	4837	9250	15170	22390
88A-100 Series	--	--	--	--	--	--	86	104	234	375	673	1099	1902	3890	--
88A-200 Series	--	--	15	19	75	--	195	410	545	1021	2016	4837	9250	15170	22390
88A-700 Series	--	--	--	--	--	--	86	104	234	375	673	1099	1902	3890	--
88A-900 Series	--	--	15	19	75	--	195	410	545	1021	2016	4837	9250	15170	22390
88A-F00 Series	--	--	--	--	75	--	195	410	545	1021	2016	4837	--	--	--
88B-100 Series	--	--	--	--	--	--	--	--	375	673	1099	1902	3890	--	--
89-100 Series	8.4	7.2	15	30	43	48	84	108	190	370	--	--	--	--	--
9A-100 Series	8.3	6.7	5.7	10	16	25	40	62	--	--	--	--	--	--	--
90-100 Series	8.3	6.7	5.7	10	16	25	40	62	--	--	--	--	--	--	--
92-100 Series	8.3	6.7	5.7	10	16	25	40	62	--	--	--	--	--	--	--
93-100 Series	8.3	6.7	5.7	10	16	25	40	62	--	--	--	--	--	--	--
94A-100/200 Series	6	7	19	34	50	104	268	309	629	1018	1622	--	--	--	--
96-100 Series	8.3	6.7	5.7	10	16	25	40	62	--	--	--	--	--	--	--
399-100 Series	8.4	7.2	15	30	43	48	84	108	190	370	--	--	--	--	--
489-100 Series	8.4	7.2	15	30	43	48	84	108	190	370	--	--	--	--	--



PRESSURE/TEMPERATURE RATINGS

ENGINEERING DATA

CLASS 150

(CS) ASTM A216-WCB

GRAPH 1

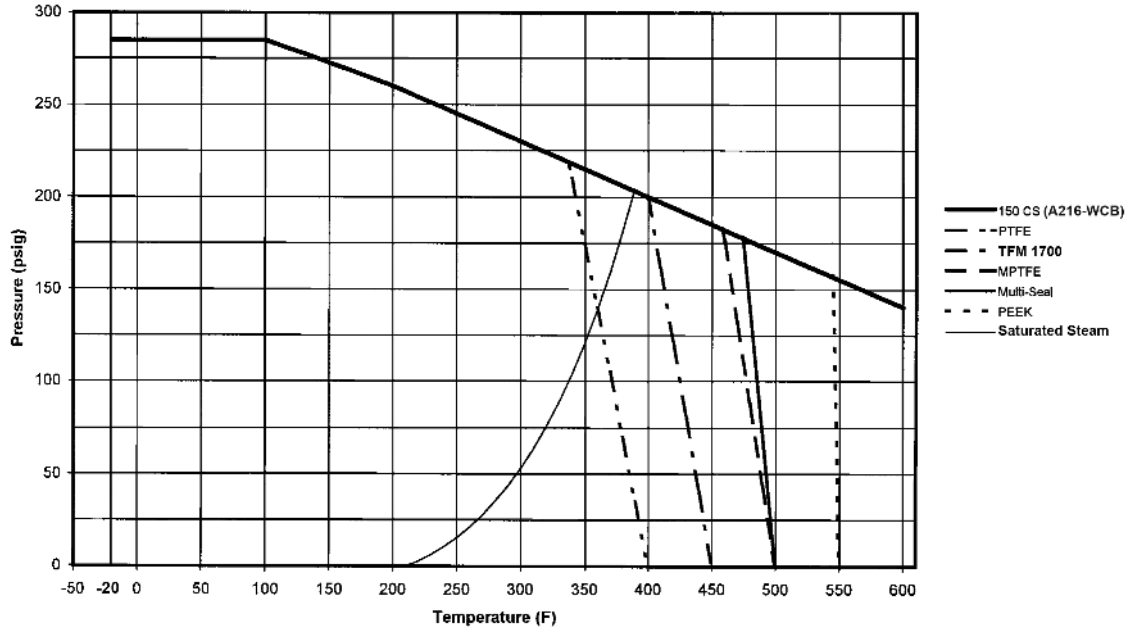

CLASS 150

(SS) ASTM A351-CF8M OR ASTM A351-CF3M

GRAPH 2

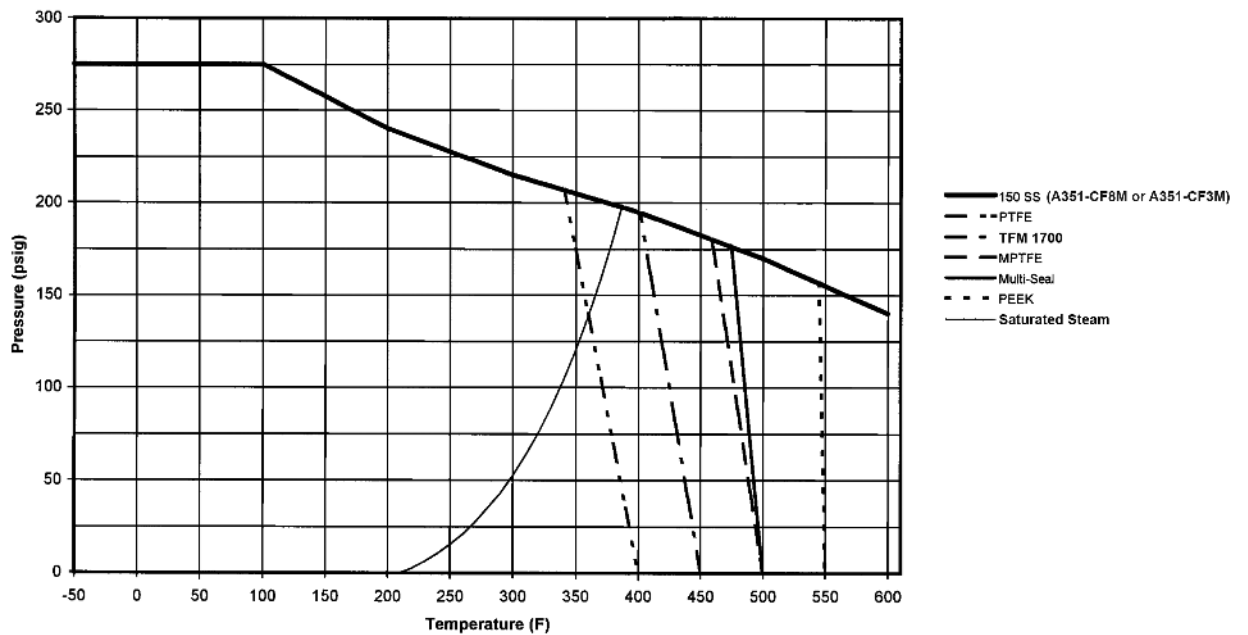



FEATURES & BENEFITS

ASME FLANGED BALL VALVES

87A, 87A-F, 87B, 88A, 88A-F, 88B, 88L, & 88L-F SERIES

STANDARDS COMPLIANCE

Except where specifically noted all valves within this family of products complies with the requirements of this listed standard.

- ASME B16.5 "Pipe Flanges and Flanged Fittings"
- ASME B16.10 "Face to Face Dimensions of Valves"
- ASME B16.34 "Valves - Flanged, Threaded, and Welding End"
- ASME B16.33 "Manual Operated Metallic Gas Valves for Use in Gas Piping Systems up to 125 psig"
- ASME B16.38 "Large Metallic Valves for Gas Distribution (Manually Operated NPS 2-1/2" to 12", 125 psig)"
- ASME B31.1 "Power Piping"
- ASME B31.3 "Chemical Plant and Petroleum Refinery Piping"
- ASME B31.8 "Gas Transmission and Distribution Piping Systems"
- API 607 "Fire Test - Soft Seated Quarter Turn Valves" (-24 Option Required). See specific tech sheet for 5th or 6th edition.
- API 608 "Ball Valves - Flanged, Threaded, and Welding End"
- MSS SP-25 "Standard Marking System for Valves"
- MSS SP-61 "Pressure Testing of Steel Valves"
- MSS SP-72 "Ball Valves with Flanged or Butt-weld Ends"
- UL 125 "Valves for Anhydrous Ammonia and LP-Gas (Other than Safety Relief)"
- NSF/ANSI/CAN 61 Section 8, Annex G (1/2" to 12" 87A Series)
- NSF/ANSI 372 Drinking Water System Components - Lead Content (1/2" to 12" 87A Series)

STANDARD FEATURES

Except where specifically noted all valves within this family of products include all listed features as standard.

- Two Position Locking Device (Valves 6" Full Port, 8" Standard Port and smaller)
- Chevron Style Adjustable Stem Seals
- ISO 5211 Mounting Pad Bolt Pattern
- Slot Vented Ball for Thermal Expansion
- Rated up to 150 psig Saturated Steam: ASME Class 150, 300, & 600 Valves
- Rated up to 250 psig Saturated Steam: ASME Class 300 Valves Require the -65 Option
- ASME Class 600 Valves Require the -24-80 Options or -38 Option
- Anti-static Grounded Ball and Stem
- Blowout-Proof Stem Design
- Cast Boss for Bleed / Drain Port
- Vacuum Service to 29 inches of Hg
- NACE MR0175 (2000) Compliance on all 87A/87B/88A/88B/88L Valves with Stainless Steel Ball & Stem
- NACE MR0103 (2003) Compliance on all 87A/87B/88A/88B/88L Valves with Stainless Steel Ball & Stem

PRODUCT APPROVALS

- **CSA* (Reference: ASME B16.33 & B16.38)**
ASME Class 150 & 300 only
 - **UL* (Reference: Control Number 195H)**
ASME Class 150 & 300 only
 - UL (YSDT) LP-Gas Shut-Off Valves
 - UL (MHKZ) Manual Valves
 - UL (YRBX) Flammable Liquid Shut-Off Valves
 - UL (YRPV) Gas Shut-Off Valves
 - UL (YQNZ) Compressed Gas Shut-Off Valves
 - UL (YQAR) Anhydrous Ammonia Shut-Off Valves
- *Requires "UL" suffix for markings.
- **CE Marking(with "-CE" suffix):**
Marking is available with all the flanged ball valves listed below
 - 87A
 - 87A (Alloy 20)
 - 87B
 - 87C
 - 87G
 - 87J
 - 87K
 - 87M
 - 87R
 - 88A
 - 88B
 - 88L