

# 86S-500 SERIES

STAINLESS STEEL 3-PIECE FULL PORT CLASS 600 SCH. 40 BUTT WELD BALL VALVE



## STANDARD COMPLIANCE

- Valve Design: ASME B16.34, Class 600, NACE MR0175 (2000) & MR0103 (2012), API 608
- End Connections: Butt-Weld per ASME B16.25

- Valve Marking: ASME B16.34
- Production Testing: ASME B16.34

## FEATURES

- 3-piece construction w/ enclosed fasteners
- Full port
- Stainless steel trim & hardware
- Swing-out center section
- Pressure balanced solid ball
- Compression controlled spiral wound gaskets
- Anti-blowout one piece bottom entry stem
- Statically grounded ball, stem, & body
- Two-position locking
- Adjustable multi-piece PTFE “V” style packing
- Fully machined ISO 5211 mounting

- Cast bosses on the center-section and end caps for bleed & drain ports
- Vacuum service to 29 in of Hg.
- CE Marking, 1.25” and larger (add “-CE” suffix)
- 250 psig saturated steam

## OPTIONS AVAILABLE

(MORE INFORMATION IN SECTION J)

- Minimum quantities apply
- To specify an option, replace the “01” standard suffix with the suffix of the option.
- To specify multiple options, replace the “01” suffix with the desired suffixes in the numerical order shown below. NOTE: Not all suffixes can be combined together.

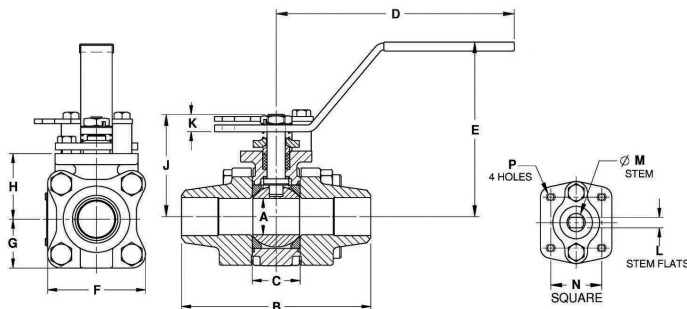

## STANDARD MATERIAL LIST

	PART	MATERIAL
1	Body	ASTM A351-CF3
2	End Caps	ASTM A351-CF3
3	Ball	ASTM A276-304/304L
4	Stem	ASTM A276-304/304L ASTM A564 17-4PH (2" with -38 suffix)
5	Seat	Multi-Seal
6	Packing	PTFE
7	Stem Bearing	PEEK/PTFE
8	Body Gasket	PTFE Spiral Wound
9	Body Bolts	ASTM A193-Gr.B8M3
10	Body Nuts	ASTM A194-Gr.8
11	Stop Bolts	18-8 Stainless Steel
12	Gland Bolts	ASTM A193-Gr.B8
13	Handle Nut/Screw	300 Series Stainless Steel
14	Packing Gland	ASTM A276-316SS
15	Gland Plate	300 Series Stainless Steel
16	Lever Handle	300 Series Stainless Steel
17	Lock Plate	300 Series Stainless Steel
18	Stops	300 Series Stainless Steel
19	Internal Grounding Spring	300 Series Stainless Steel
20	External Grounding Spring	300 Series Stainless Steel

(SUFFIX)	OPTION	SIZES
-01	Standard Configuration	All
-04-	2.25" Stem Extension (Carbon Steel, Zinc Plated)	1/2" to 2"
-14-	Vented Ball	1/2" to 2"
-15-	Stainless Steel Locking Round Handle	1/2" to 2"
-21-	UHMWPE Seats w/ Graphite Seals	1/2" to 2"
-24-	Graphite Packing, Spiral Wound Graphite Body Seal, PTFE/PEEK Bearing (Fire Safe API 607, 6th Edition, ISO 10497:2010) (Fire Safe by Design)	1/2" to 2"
-38-	PEEK Seats, Graphite Stem Packing & Gaskets	1/2" to 2"
-49-	No Lubrication. Assembled Dry	1/2" to 2"
-57-	Cleaned for Oxygen Service	1/2" to 2"
-62-	Center Section Only	1/2" to 2"
-66-	FNPT x Butt weld	1/2" to 2"
-69-	Drilled & Tapped Purge & Drains	1/2" to 2"
-70-	4" Extended Bonnet	1/2" to 2"
-76-	Live Loaded (Lever Operated)	1/2" to 2"
-77-	Live Loaded (Actuated)	1/2" to 2"
-90-	Double Packed 4" Extended Bonnet	1/2" to 2"
-9P-	Double Packed 4" Extended Bonnet w/ Monitoring Port	1/2" to 2"
-CE-	CE Marking	1-1/4" to 2"
-KF-	PCTFE Stem Bearing	1/2" to 2"
-SR-	Spring Return Handle	1/2" to 1"

**Pressure/Temperature Ratings - Page M-31, Graph No. 46**

## DIMENSIONS

PRODUCT NO.	SIZE	A	B	C	D	E	F	G	H	J	K	L	M	N	P	WT.
86B-503-01	1/2"	0.50	3.80	0.89	5.12	3.02	2.02	1.01	1.39	1.97	0.23	0.245	0.375	1.00	10-24	2.3
86B-504-01	3/4"	0.75	4.66	1.10	5.53	3.40	2.40	1.20	1.65	2.35	0.24	0.312	0.500	1.392	1/4-20	4.0
86B-505-01	1"	1.00	5.19	1.31	6.53	4.80	2.67	1.34	1.80	2.80	0.48	0.287	0.500	1.392	1/4-20	5.7
86B-507-01	1.5"	1.50	5.96	1.97	6.65	4.70	3.84	1.92	2.49	3.89	0.72	0.412	0.625	1.949	5/16-18	14.4
86B-508-01	2"	2.00	6.84	2.56	8.40	5.47	4.56	2.46	3.17	4.74	0.80	0.477	0.750	1.949	5/16-18	24.4

The listed  $C_v$  “factors” are derived from actual flow testing, at Apollo’s Pageland, South Carolina factory. These tests were completed using standard “off the shelf” valves with no special preparation and utilizing standard schedule 40 pipe. It should be understood that these factors are for the valve only and also include the connection configuration. The flow testing is done utilizing water as a fluid media and is a direct statement of the gallons of water flowed per minute with a 1psig pressure differential across the valve/connection unit. Line pressure is not a factor. Because the  $C_v$  is a factor, the formula can be used to estimate flow of most media for valve sizing.

### FLOW OF LIQUID

$$Q = C_v \sqrt{\frac{\Delta P}{SpGr}}$$

$$\text{or } \Delta P = \frac{(Q)^2 (SpGr)}{(C_v)^2}$$

#### WHERE:

- Q = Flow in US gpm
- ΔP = Pressure drop (psig)
- SpGr = Specific gravity at flowing temperature
- $C_v$  = Valve constant

### FLOW OF GAS

$$Q = 1360 C_v \sqrt{\frac{(\Delta P) (P_2)}{(SpGr) (T)}}$$

$$\text{or } \Delta P = \frac{5.4 \times 10^{-7} (SpGr) (T) (Q)^2}{(C_v)^2 (P_2)}$$

#### WHERE:

- Q = Flow in SCFH
- ΔP = Pressure drop (psig)
- SpGr = Specific gravity (based on air = 1.0)
- P2 = Outlet pressure-psia (psig + 14.7)
- T = (temp. °F + 460)
- $C_v$  = Valve constant

**CAUTION:** The gas equation shown, is valid at very low pressure drop ratios. The gas equation is NOT valid when the ratio of pressure drop (ΔP) to inlet pressure (P1) exceeds 0.02.

**NOTE:** Only use the gas equation shown if (P1-P2)/P1 is less than 0.02.

### CV FACTORS FOR APOLLO® VALVES (CONTINUED ON M-4)

VALVE	SIZE (IN.)														
	1/4	3/8	1/2	3/4	1	1.25	1.5	2	2.5	3	4	6	8	10	12
70B-140 Series	8.4	7.2	15	30	43	48	84	108	190	370	670	--	--	--	--
70-100/200 Series	8.4	7.2	15	30	43	48	84	108	190	370	670	--	--	--	--
70-300/400 Series	--	--	15	30	43	48	84	108	--	--	--	--	--	--	--
70-600 Series	2.3	4.5	5.4	12	14	21	34	47	--	--	--	--	--	--	--
70-800 Series	8.4	7.2	15	30	43	48	84	--	--	--	--	--	--	--	--
71-AR Series	--	--	--	30	43	48	84	108	190	370	--	--	--	--	--
71-100/200 Series	--	--	--	30	43	48	84	108	190	370	--	--	--	--	--
72-100/900 Series	--	--	26	48	65	125	170	216	--	--	--	--	--	--	--
72-1xx-A/72-9xx-A Series	--	--	26	48	65	125	170	245	--	--	--	--	--	--	--
73A-100 Series	8.4	7.2	15	30	43	48	84	108	--	--	--	--	--	--	--
73-300/400 Series	--	--	26	48	65	125	170	216	--	--	--	--	--	--	--
74-100 Series	8.4	7.2	15	30	43	48	84	108	190	370	670	--	--	--	--
75-100 Series	8.4	7.2	15	30	43	48	84	108	190	370	670	--	--	--	--
76-AR Series	8.4	7.2	15	30	43	48	84	108	190	370	670	--	--	--	--
76F-100 Series	8.1	15	15	51	68	125	177	389	--	--	--	--	--	--	--
76FJ-100 Series	8.1	15	15	51	68	125	177	389	--	--	--	--	--	--	--
76FK-100 Series	8.1	15	15	51	68	125	177	389	--	--	--	--	--	--	--
76-100 Series	8.4	7.2	15	30	43	48	84	108	190	370	--	--	--	--	--
76-300/400 Series	--	--	26	48	65	125	170	216	--	--	--	--	--	--	--
76-600 Series	2.3	4.5	5.4	12	14	21	34	47	--	--	--	--	--	--	--
76J-100 Series	8.4	7.2	15	30	43	48	84	108	190	370	--	--	--	--	--
76J-AR Series	8.4	7.2	15	30	43	48	84	108	190	370	670	--	--	--	--
76K-100 Series	8.4	7.2	15	30	43	48	84	108	190	370	--	--	--	--	--
76K-AR Series	8.4	7.2	15	30	43	48	84	108	190	370	670	--	--	--	--
7K-100 Series	--	--	15	51	68	125	177	389	503	--	--	--	--	--	--
77-AR Series	8.1	15	15	51	68	--	177	389	--	--	--	--	--	--	--

## CV FACTORS FOR APOLLO® VALVES (CONTINUED FROM M-3)

VALVE	SIZE (IN.)														
	1/4	3/8	1/2	3/4	1	1.25	1.5	2	2.5	3	4	6	8	10	12
77C-100/200 Series	4.5	7.2	16	36	68	125	177	389	503	--	--	--	--	--	--
77D-140 Series	4.5	7.2	16	36	68	125	177	389	--	--	--	--	--	--	--
77D-640 Series	--	--	--	11	24	35	--	--	--	--	--	--	--	--	--
77G-UL Series	4.5	7.2	16	36	68	125	177	389	503	--	--	--	--	--	--
77W Series	--	--	16	36	68	125	177	389	--	--	--	--	--	--	--
77-100/200 Series	8.1	15	15	51	68	125	177	389	503	--	--	--	--	--	--
79 Series	8.5	8.5	9.8	32	44	66	148	218	440	390	--	--	--	--	--
80 Series	8.4	7.2	15	30	43	48	84	108	190	370	--	--	--	--	--
82-100/200 Series	8.1	14	26	51	68	120	170	376	510	996	1893	--	--	--	--
83A/83B Series	8.1	14	26	51	68	120	170	376	--	--	--	--	--	--	--
83R-100/200 Series	--	--	--	--	--	--	170	376	--	996	1893	--	--	--	--
86A/86B Series	8.1	14	26	51	68	120	170	376	--	--	--	--	--	--	--
86R-100/200 Series	--	--	--	--	--	--	170	376	--	996	1893	--	--	--	--
87A-100 Series	--	--	--	--	--	--	86	104	234	375	673	1099	1902	3890	--
87A-200 Series	--	--	15	19	75	--	195	410	545	1021	2016	4837	9250	15170	22390
87A-700 Series	--	--	--	--	--	--	86	104	234	375	673	1099	1902	3890	--
87A-900 Series	--	--	15	19	75	--	195	410	545	1021	2016	4837	9250	15170	22390
87A-F00 Series	--	--	--	--	75	--	195	410	545	1021	2016	4837	--	--	--
87B-100 Series	--	--	--	--	--	--	--	--	--	375	673	1099	1902	3890	--
87J-100 Series	--	--	--	--	--	--	86	104	234	375	673	1099	1902	3890	--
87J-200 Series	--	--	15	19	75	--	195	410	545	1021	2016	4837	9250	15170	22390
87J-700 Series	--	--	--	--	--	--	86	104	234	375	673	1099	1902	3890	--
87J-900 Series	--	--	15	19	75	--	195	410	545	1021	2016	4837	9250	15170	22390
87K-100 Series	--	--	--	--	--	--	86	104	234	375	673	1099	1902	3890	--
87K-200 Series	--	--	15	19	75	--	195	410	545	1021	2016	4837	9250	15170	22390
87K-700 Series	--	--	--	--	--	--	86	104	234	375	673	1099	1902	3890	--
87K-900 Series	--	--	15	19	75	--	195	410	545	1021	2016	4837	9250	15170	22390
88A-100 Series	--	--	--	--	--	--	86	104	234	375	673	1099	1902	3890	--
88A-200 Series	--	--	15	19	75	--	195	410	545	1021	2016	4837	9250	15170	22390
88A-700 Series	--	--	--	--	--	--	86	104	234	375	673	1099	1902	3890	--
88A-900 Series	--	--	15	19	75	--	195	410	545	1021	2016	4837	9250	15170	22390
88A-F00 Series	--	--	--	--	75	--	195	410	545	1021	2016	4837	--	--	--
88B-100 Series	--	--	--	--	--	--	--	--	--	375	673	1099	1902	3890	--
89-100 Series	8.4	7.2	15	30	43	48	84	108	190	370	--	--	--	--	--
9A-100 Series	8.3	6.7	5.7	10	16	25	40	62	--	--	--	--	--	--	--
90-100 Series	8.3	6.7	5.7	10	16	25	40	62	--	--	--	--	--	--	--
92-100 Series	8.3	6.7	5.7	10	16	25	40	62	--	--	--	--	--	--	--
93-100 Series	8.3	6.7	5.7	10	16	25	40	62	--	--	--	--	--	--	--
94A-100/200 Series	6	7	19	34	50	104	268	309	629	1018	1622	--	--	--	--
96-100 Series	8.3	6.7	5.7	10	16	25	40	62	--	--	--	--	--	--	--
399-100 Series	8.4	7.2	15	30	43	48	84	108	190	370	--	--	--	--	--
489-100 Series	8.4	7.2	15	30	43	48	84	108	190	370	--	--	--	--	--

**ASME CLASS 600**

**(SS) ASTM A351-CF3**

**GRAPH 46**

