

34E Series

Emergency Eyewash Mixing Valve

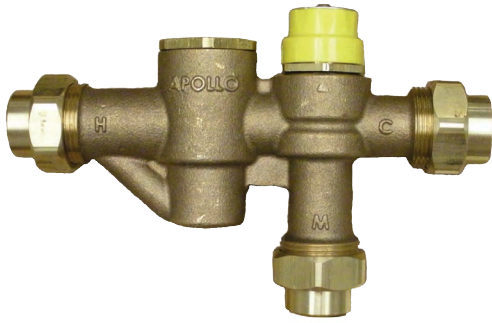

Job Name:	
Job Location:	
Engineer:	
Contractor:	
Tag:	
PO#:	
Rep:	
Wholesale Dist.:	

DESCRIPTION

The Apollo 34E Series Emergency Mixing Valves are designed to ensure safe and reliable delivery of tepid water to emergency eyewash / face wash fixtures. The device includes a patented temperature and flow control feature in the event of cold water, hot water and thermostatic element failures.

FEATURES

- Patented Hot and Cold Water Supply Failure Protection (US Patent 6,926,205 B2)
- Tepid Water Temperature Limit Control
- Locking Handle for Tamper-Proof Protection
- Integral Inlet Check Valves and Strainers
- Superior Thermostatic Element Technology
- Thermostatic Element Over-Travel Protection
- 100% Factory Tested and Pre-Set to 85°F (29.4°C)
- In-Line Accessibility and Serviceability
- Corrosion, Dezincification and Scale Resistant Materials
- **Made in USA**

OPTIONS

- Size: 1/2" or 3/4"
- Inlets: FNPT or Solder
- Outlet: FNPT or Solder
- Outlet Temperature Gauge
- Hot and Cold Inlet Shut-off Ball Valves
- Rough Chrome Finish
- (34ELF Series) Lead Free (0.25% Lead Max) (Select Models)

APPROVALS

- ASSE 1071-2008
Temperature Actuated Mixing Valves for Plumbed Emergency Equipment
- ANSI/ISEA Z358.1 2009
Emergency Eyewash & Shower Equipment

STANDARD MATERIALS LIST

BODY	ASTM B584 Bronze
SHUTTLE	Noryl®
THERMOSTAT	Brass/Wax filled
O-RING	Chloramine Resistant EPDM
SPRING	ASTM A313 Stainless Steel
CAP	ABS Polymer
MODULE COMPONENTS	Noryl®

DIMENSIONS

PART NUMBER	SIZE CONNECTION	DIMENSIONS (IN.)							WT. (LB.)
		A	B	C	D	E	F	G	
34E113T	1/2" FPT	3.09	8.90	2.66	3.60	3.45	5.77	7.83	3.94
34E113S	1/2" Solder	3.22	9.15	2.66	3.60	3.45	5.77	7.83	3.73
34E114T	3/4" FPT	3.09	8.90	2.67	3.60	3.45	6.32	8.39	5.13
34E114S	3/4" Solder	3.10	8.90	2.67	3.60	3.45	6.32	8.39	5.07

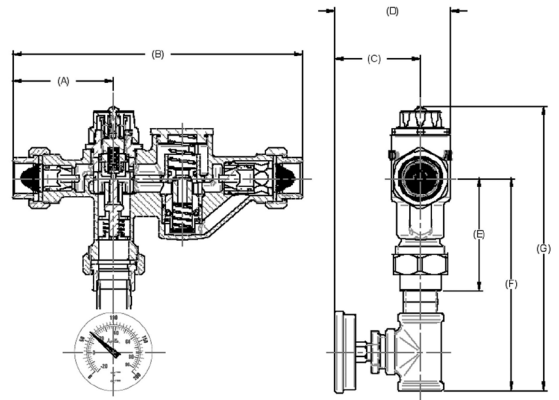

34E Series

Emergency Eyewash Mixing Valve

PERFORMANCE RATING

- Maximum Working Pressure: 150 psig (1034 kPa)
- Hot Water Inlet Temperature Range: 120 - 180 °F (49 - 82 °C)
- Cold Water Inlet Temperature Range: 40 - 70 °F (4.4 - 21 °C)
- Tepid Water Temperature Adjustment Range: 65 - 95 °F (18.3 - 35 °C)
- Mixed Water Temperature Tolerance: ±5 °F (±2.8 °C)
- Max. Flow Rate @ 30 psi (207 kPa) Differential: 15 GPM (56.8 LPM)
- Cold Water Bypass @ 30 psi (207 kPa) Differential: 13.5 GPM (51 LPM)
- Minimum Flow Rate: 1.5 GPM (5.6 LPM)

(Note: The cold water supply shall be at least 20 °F (-6.7 °C) lower than the outlet water temperature setting)

FLOW CURVES

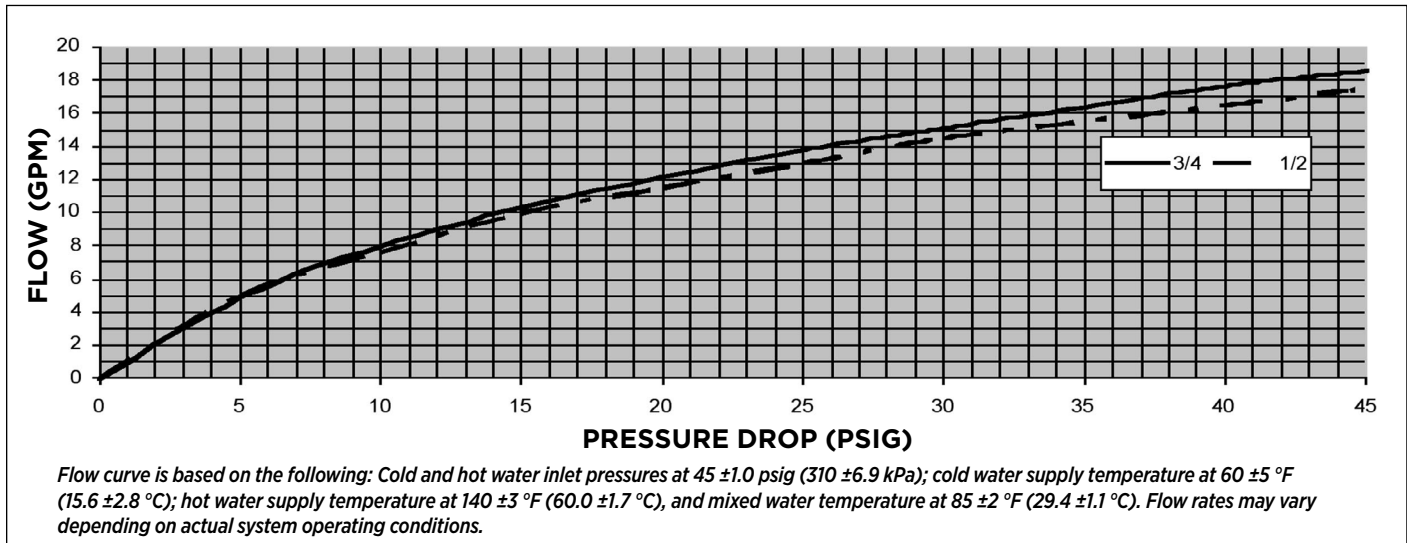

34ELF TYPICAL INSTALLATIONS:

- Note: Piping and installation of the device must be in accordance to federal, state, and local plumbing codes.
- Note: If the valve is some distance from the hot water source, recirculation is required to keep the hot water supply temperature within the required operational limits

